

SKYDECK

Panel Slab Formwork

Assembly Instructions for Standard Configuration

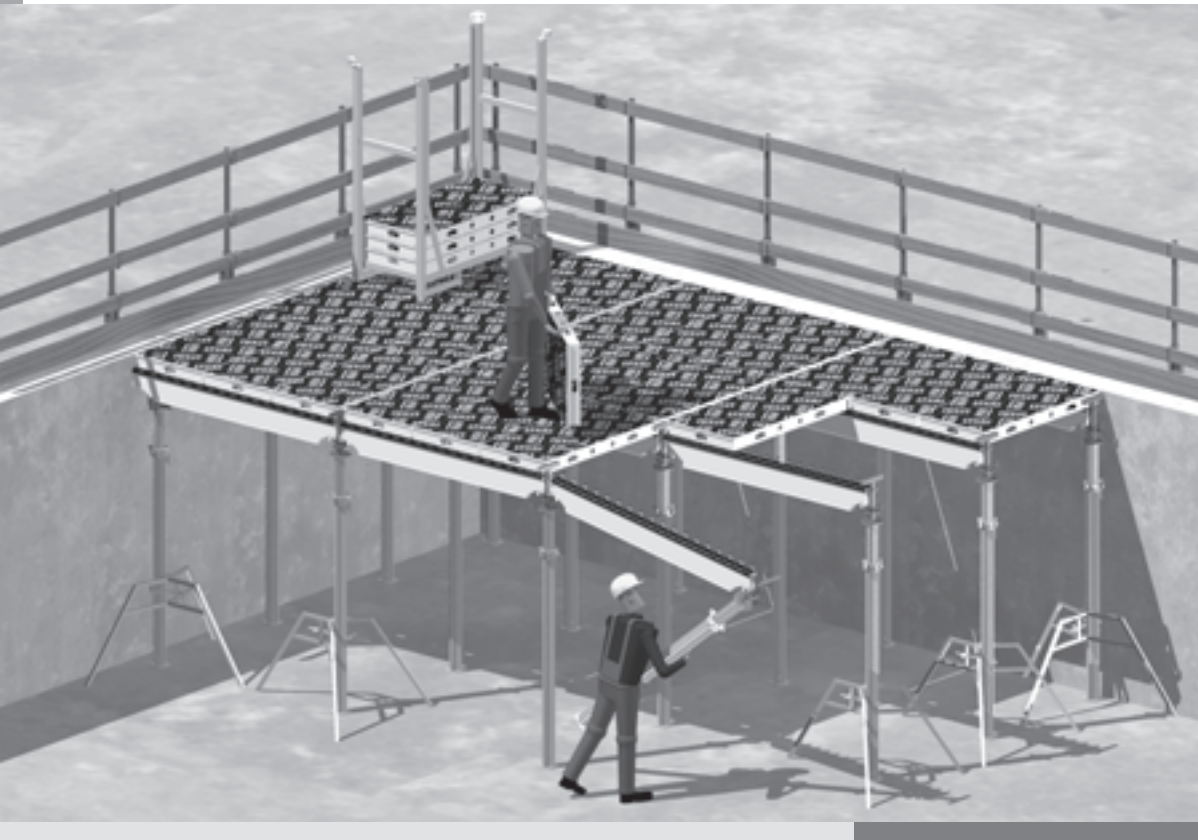

Contents

Overview			Tables	
Overview	1		With Drophead SFK	28
Introduction			With Prophead SSK	29
Standard configuration	2		Panel system, striking guide values	30
Intended use	2		Infill areas	31
Safety instructions	3		Slab Props PEP 20	32
Additional PERI product information	3		Slab Props PEP 30	33
			Slab Props MULTIPROP	34
A Assembly and dismantling			Components	
A1 Storage and transportation	4		Components	36
A2 System components	5			
A3 Shuttering	6			
A4 Infills				
Longitudinal infills	10			
Transverse infills	11			
Edge Beam SRT, Triangular Frame SDR	12			
Combihead SCK	13			
A5 Shuttering of columns				
1 Recessed panels	16			
2 Recessed panels	17			
3 Recessed panels	18			
Recessed main beams	19			
A6 Guardrails				
On open building edges	20			
On casting segments	21			
A7 Striking	22			
A8 Maintenance and cleaning	24			
A9 System dimensions	25			
A10 Site record	26			

Key



Important safety Instructions



Hints



Visual Check



Site Tips

SKYDECK Panel Slab Formwork

Overview

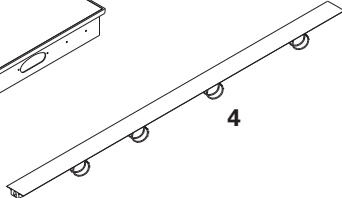
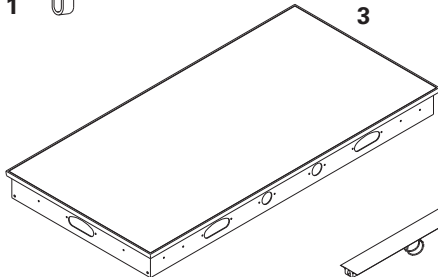
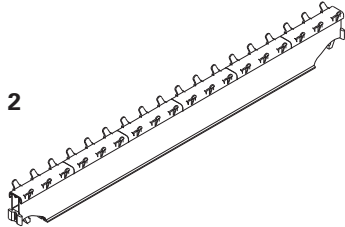
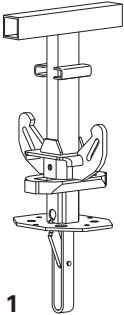
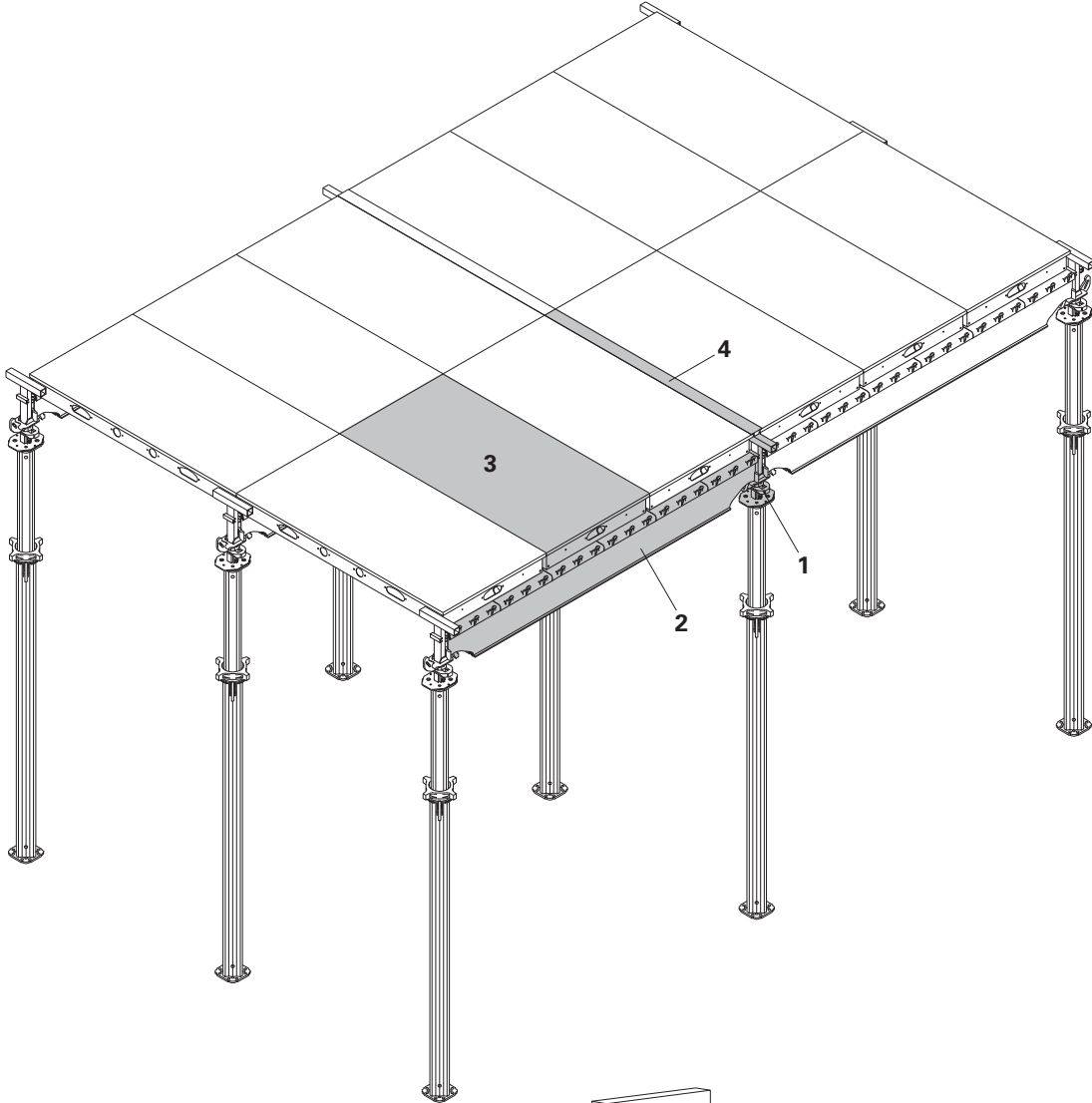

- 1 Drophead SFK
- 2 Main Beam SLT 225
- 3 Panel SDP
- 4 Cover Strip SAL

Introduction

Standard configuration

General

The structures presented in these assembly instructions are shown in the form of examples with only one component size. They are valid accordingly for all component sizes contained in the standard configuration.

Features

PERI SKYDECK is a panel slab formwork system used for constructing slab thicknesses up to 95 cm. Depending on the slab thickness and concrete strength, the SKYDECK drophead allows striking to take place after only 1 day (see table containing minimum concrete strength and guide values).

The panels and main beams are made of aluminium which means they are very light.

Accessories for infill areas, shuttering around columns and the slab edges are also available.

Due to early striking, the panels and main beams can be used for the new concreting cycle.

Only the props with dropheads and the cover strips remain in position until the

full concrete strength has been reached. The on-site material requirements are therefore clearly reduced.

Main components

Drophead SFK
Prophead SSK
Combihead SCK

Panel SDP in the following sizes:

150 x 75, 150 x 50, 150 x 37.5, 75 x 75, 75 x 50, 75 x 37.5 cm

Main Beam SLT in the following lengths:

225, 150, 375 cm

Cover Strip in the following lengths:

150, 75, 50, 37.5 cm

Technical Data

Permissible slab thicknesses and available prop loads: see PERI Tables.

System dimensions

With Drophead SFK, Main Beam SLT 225

230 x 150 cm, slab thickness max. 40 cm (presented in the following)

230 x 75 cm, slab thickness max. 80 cm

115 x 75 cm, slab thickness max. 95 cm (with centre support)

With Drophead SFK, Main Beam SLT 150

155 x 150 cm, slab thickness max. 48 cm

155 x 75 cm, slab thickness max. 95 cm

With Prophead SSK, Main Beam SLT 225

225 x 150 cm, slab thickness max. 40 cm

225 x 75 cm, slab thickness max. 80 cm

112.5 x 75 cm, slab thickness max. 95 cm (with centre support)

With Prophead SSK, Main Beam SLT 150

150 x 150 cm, slab thickness max. 51 cm

150 x 75 cm, slab thickness max. 95 cm

Intended use

1. PERI products are exclusively technical working materials which are intended for commercial use by technically competent users only.

2. These assembly instructions serve as the basis for the project-related risk assessment and the instructions for the provision and use of the system by the contractor (user). However, they do not replace these.

3. Only PERI original components may be used. The use of other products and spare parts represents a misapplication with associated safety risks.

4. The components are to be inspected before each use to ensure that they are in perfect condition and function correctly.

5. Changes to PERI components are not permitted and represent a misapplication with associated safety risks.

6. Safety instructions and permissible loads must be observed.

7. Components provided by the contractor must conform with the characteristics required in these assembly instructions as well as all valid construction guidelines and standards.

In particular, the following apply if nothing else is specified:

- timber components: Strength Class C24 for Solid Wood EN 338.
- scaffold tubes: galvanised steel tubing with minimum dimensions Ø 48.3 x 3.2 mm according to EN 12811-1:2003 4.2.1.2.
- scaffold tube couplings according to EN 74.

8. Deviations from the standard configuration may only be carried out after a separate risk assessment has been done by the contractor (user). On this basis, appropriate measures for the working safety and stability are to be implemented.

Introduction

Safety instructions

General

1. Deviations from the standard configuration and/or intended use present a potential safety risk.
2. All country-specific laws, standards and other safety regulations are to be taken into account when products are used.
3. During unfavourable weather conditions, suitable precautions and measures are to be implemented in order to guarantee working safety and stability.
4. The contractor (user) must ensure the stability throughout all phases of construction. He has to ensure and verify that all loads which occur are safely transferred.
5. The contractor (user) has to provide safe working areas for site personnel which are to be reached via safe access means. Areas of risk must be cordoned off and clearly marked. Hatches and openings on accessible working areas must be kept closed during working operations.
6. For better comprehensibility, detailed representations are partly incomplete. The safety installations which have possibly not been shown in these detailed descriptions must nevertheless be available.

Storage and transportation

1. Do not drop the components.
2. Store and transport components so that no unintentional change in their position is possible. Detach lifting gear from the lowered units only if these are in a stable position and no unintentional change is possible.
3. When moving, components are to be picked up and set down so that any unintentional toppling over, falling apart, slipping or rolling are avoided.
4. Use only suitable load-carrying equipment to move the components as well as the designated load-bearing points.
5. During the lifting and moving procedure, ensure all loose parts are removed or secured.
6. During the moving procedure, always use a guide rope.
7. Move components only on clean, flat and sufficiently load-bearing surfaces.

System-specific

1. Retract components only when the concrete has sufficiently hardened and the person in charge has given the go-ahead for striking to take place.
2. Anchoring is to take place only if the anchorage has sufficient concrete strength.
3. During striking, do not tear off the formwork elements with the crane.
4. The existing prop loads (see tables) must be safely transferred by means of sufficiently load-bearing slab props or tower systems.
5. The SKYDECK platforms are classified in Load Class 2 (permissible load 150 kg/m²). They are available as work and safety scaffold.
6. When storing heavy items on the formwork, the load-bearing capacity must be taken into consideration.
7. Cantilevers may only be accessed after bracing has been mounted.
8. The horizontal fixed position of the slab formwork must be guaranteed. This is provided through circumferential walls and pre-concreted beams. Otherwise the transfer of the horizontal loads must be guaranteed by means of other measures supplied by the contractor, e. g. bracing. Load assumptions for horizontal loads in accordance with DIN EN 12812.
9. For use within Falsework Group III, a site record, according to A 10, must be made.

Additional PERI product information

- SKYDECK brochure
- SKYDECK poster
- SKYDECK platform
“Assembly Instructions”
- PERI design tables
- Pallet lifting trolley
“Instructions for Use”
- Pallet and stacking device
“Instructions for Use”
- Stripping Cart ASW 465
“Instructions for Use”
- Stripping Cart Alu
“Instructions for Use”
- Transportation Fork SKYDECK SUG
“Instructions for Use”

A1 Storage and transportation



Instructions for Use for PERI pallets and stacking devices must be taken into consideration!

Manually-created transport units must be correctly stacked and secured!

Pallets and stacked components are to be protected against the effects of the weather, e.g. secure packed components with tension straps against lifting!

Transportation

PERI pallets and stacking devices are suitable for lifting with a crane or forklift. They can also be moved with the PERI pallet lifting trolley. All pallets and stacking devices can be lifted using both the longitudinal and front sides.

The following are just some examples.

Stacked with Panel SDP 150 x 75

- Pallet SD: 48 pieces (Fig. 1)
- Pallet SD: 14 pieces (Fig. 2)

The Pallet SD can also be used for storing other SKYDECK components, e.g. Main Beam SLT. (Fig. 3)

Stacking:

2 loaded pallets, one on top of the other.

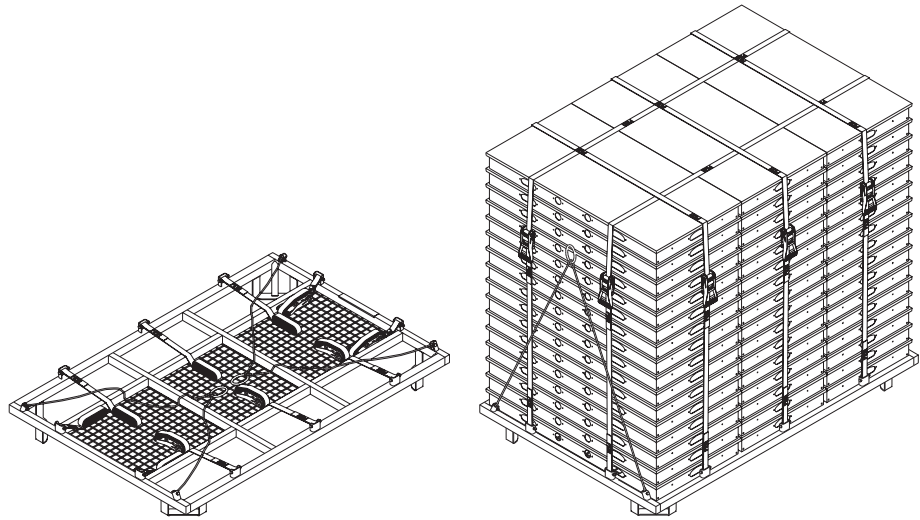

Fig. 1

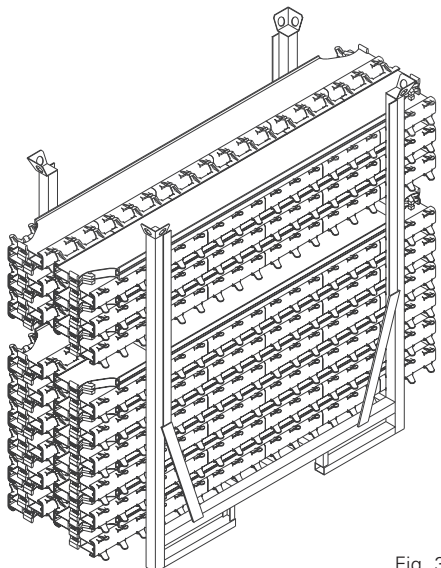

Fig. 3

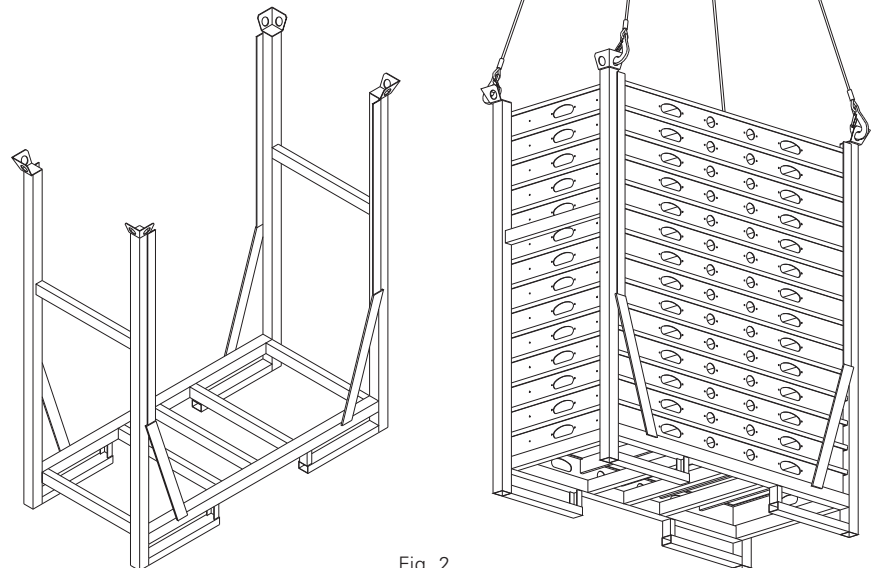

Fig. 2

A2 System components

Slab Props

Dropheads, propheads or combiheads fit on props with a hole diameter \varnothing 38 – 40 mm.

With hole diameters $>$ 40 mm, the heads must be bolted diagonally using 2 bolts ISO 4016 M 12 x 40-4.6 Mu, galv., Item no. 035440.



For prop loads over 33.3 kN, bolting on the drophead is not required with the use of MULTIPROP slab props.

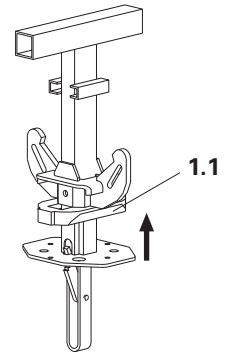
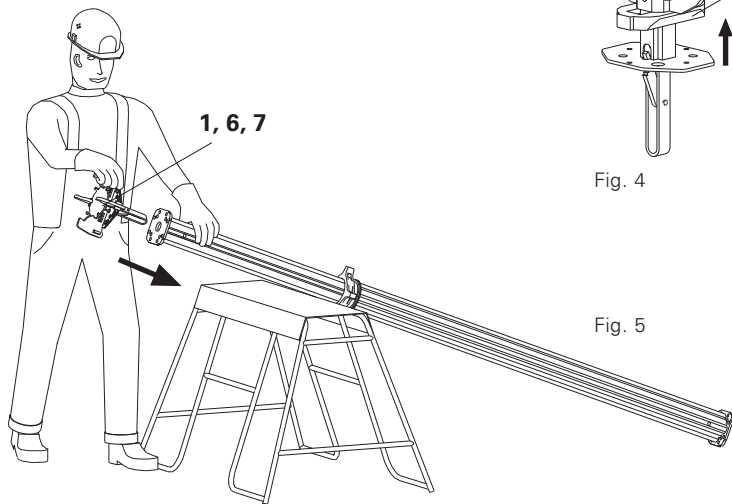

Fig. 4

Fig. 5

Preparing the slab props

1. Adjust the extension lengths of the props. Clear room height minus dimension x .
 2. Push drophead wedge (1.1) upwards. (Fig. 4)
 3. Secure with hammer blow = shuttering position.
 4. Insert drophead (1), prophead (6) or combihead (7) into the prop. The self-locking coupling is secured automatically. (Fig. 5)
- The prop is ready for use.

Start field

Main Beam SLT 225

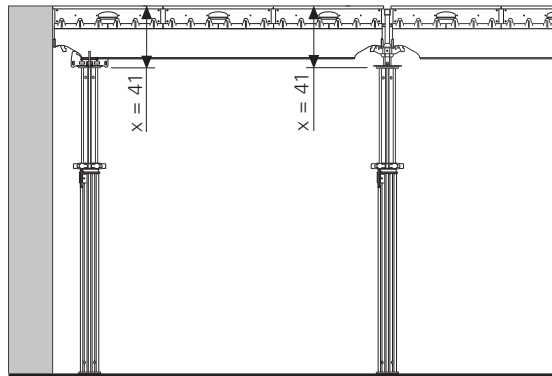

End field

Main Beam SLT 225

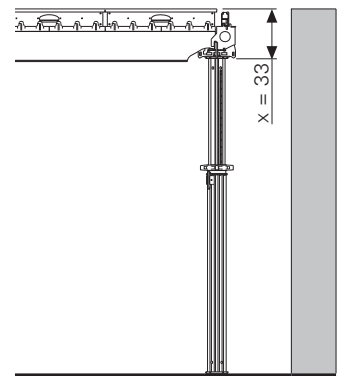

Start field

Main Beam SLT 150

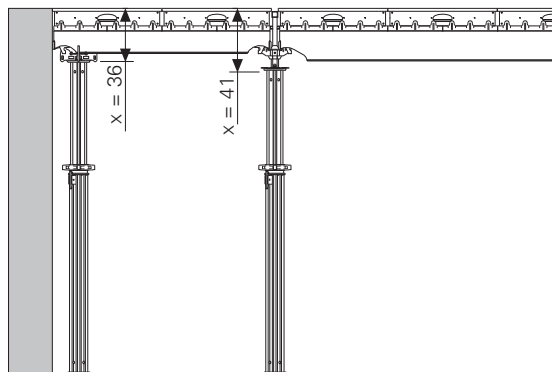

End field

Panel SDP

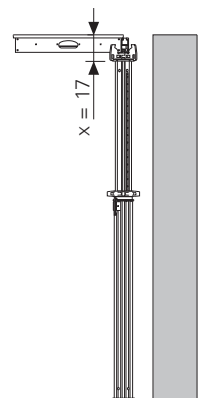

A3 Shuttering

Start field

1. Position prop with prophead (6) in one corner of the room (spacing: see Fig. 12).
2. Secure with tripod.
3. Position prop with drophead (1).
- Spacing 2.275 m.
4. Insert Main Beam SLT 225 (2) into the beam support of the prophead and drophead. (Fig. 9a, 9b, 9c)
5. Secure with tripod.
6. Position second pair of props at a distance of 1.50 m from the wall.
7. Insert Main Beam SLT 225 (2) in the beam support. (Fig. 10)

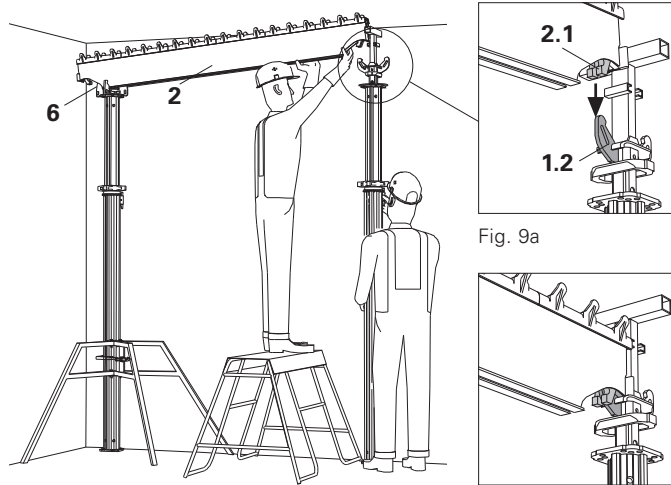

Fig. 9

Fig. 9a

Fig. 9b

Fig. 9c



Connecting the main beam

The Main Beam SLT must be positioned in the beam support centres of the SKYDECK heads. The main beam connection (2.1) enclose the head of the beam support (1.2).

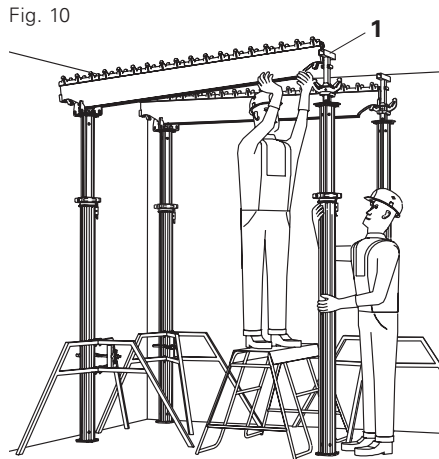
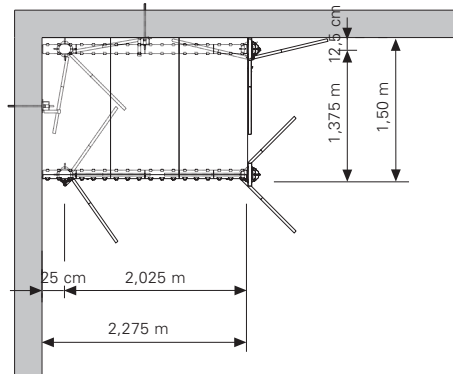

Fig. 10

Fig. 12



Insert panels

1. Spray the edge of the panel with release agent.
2. Insert panel (3). In so doing, the rack of the main beam fixes the panel in position. (Fig. 11)

The start field is complete. (Fig. 12)



Set up drophead props on the wall so that the drophead wedge can be struck from the inside during striking. The Main Beam SLT is always positioned parallel to the longer wall side. Always check the rectangularity of the first field.

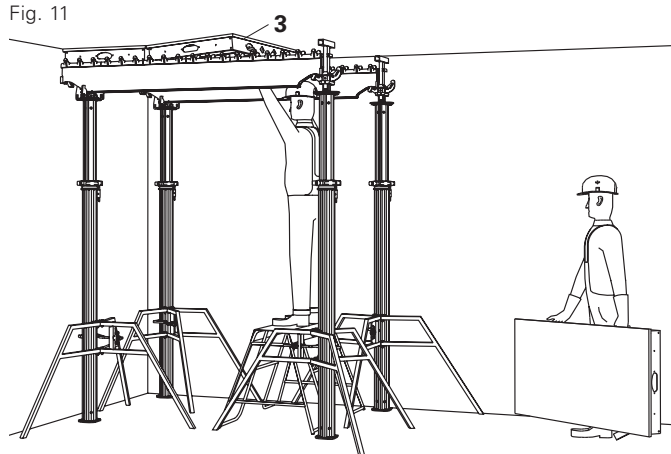

Fig. 11

A3 Shuttering

Wall Holder SWH



The area to be formed may not be accessed before the formwork has been horizontally anchored!

The Wall Holder SWH (8) is used to hold the slab formwork in a horizontal position during the assembly. It is installed in longitudinal and transverse directions and can fix the main beam as well as the panel. The Wall Holder SWH (8) is mounted in every second field.

Assembly

1. Push tie rod with Wingnut Pivot Plate through the available tie hole.
 2. Place Main Beam SLT into the Wall Holder SWH or push Wall Holder in SWH into the edge of the panel.
 3. Tighten Wall Holder SWH with Wingnut Pivot Plate on the wall.
 4. Remove tripod.
- (Fig. 14)

Fig. 14

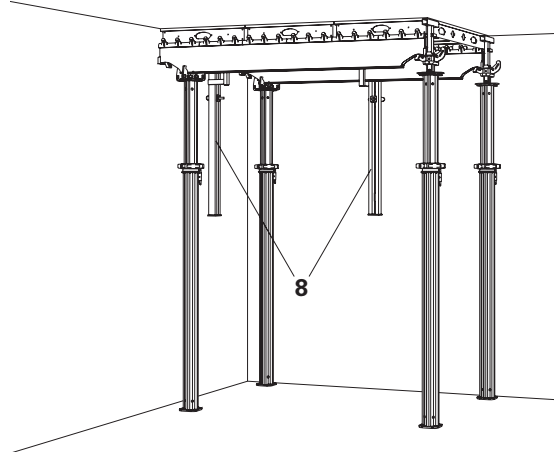

Transverse field

1. Position prop with prophead (6).
 - Spacing 1.50 m.
 2. Secure with tripod.
 3. Position prop with drophead (1).
 - Spacing 2.275 m.
 4. Insert Main Beam SLT 225 (2) into the beam support of the prophead and drophead. (Fig. 15)
 5. Secure with tripod.
 6. Insert panel (3).
- (Fig. 16)

Fig. 15

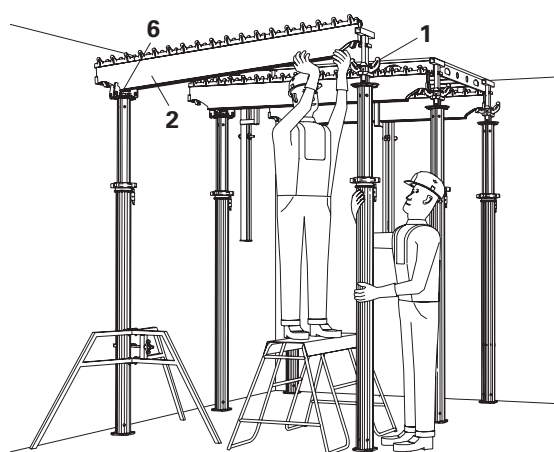

Fig. 16

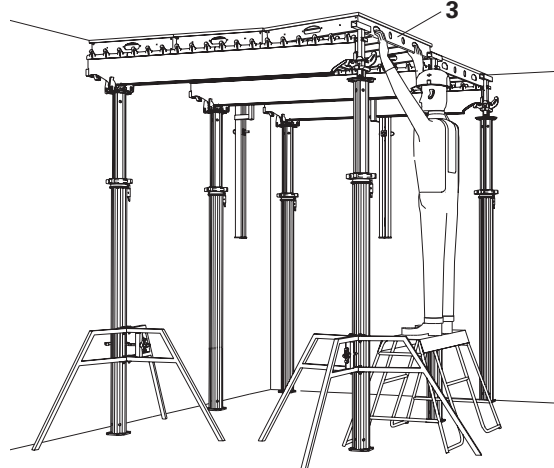
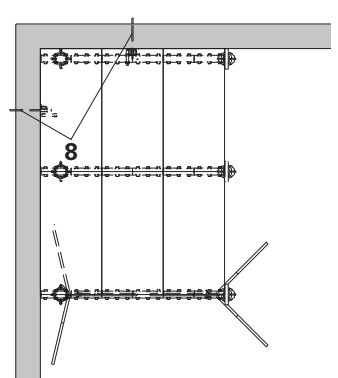

Fig. 17



The transverse field is complete. (Fig. 17)



Working in a transverse direction is recommended. Use tripods again in the next field.

A3 Shuttering

Longitudinal field



Based on the risk assessment, the contractor must decide whether forming takes place from above or below!

1. Attach Main Beam SLT 225 (2) to the drophead.
2. Connect prop with drophead in the raised main beam.
3. Place prop in a vertical position.
4. Secure with tripod.
- (Fig. 18)
5. Proceed likewise with the second main beam and prop.
6. Install panel (3).
- (Fig. 19)

The longitudinal field is now complete.
(Fig. 20)

Mount a wall holder (8) in every second field.
Use tripods in the next field again.

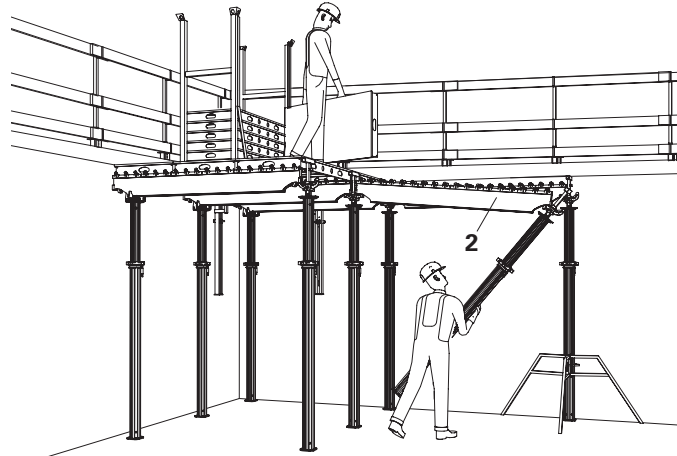

Fig. 18

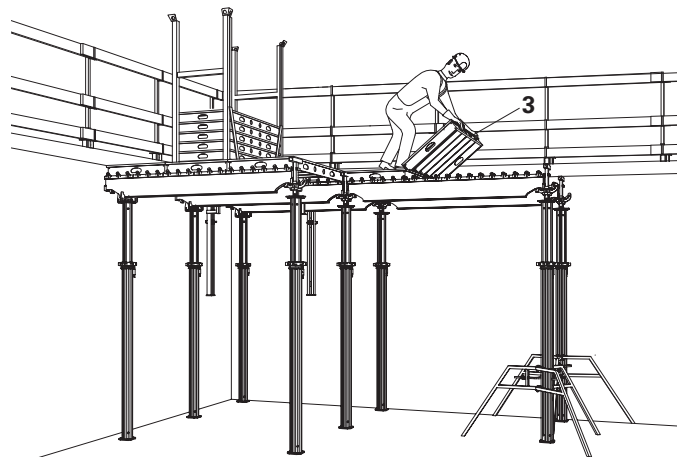

Fig. 19



If the SKYDECK Guardrail Holder is used, this must be installed during setting of the panels. For details see A6.

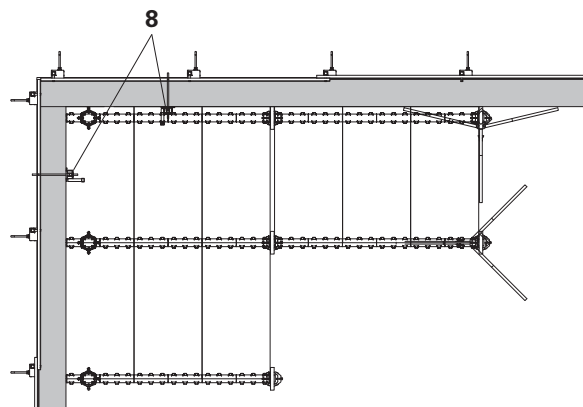

Fig. 20

A3 Shuttering

Standard field

Due to the recurring assembly sequence, always continue in the same way.



With wind speeds of 64 km/h upwards, reinforcement is to be carried out immediately or the panels are to be fixed to the main beams by means of 2 Panel Clips SPK (21) respectively. (Fig. 22a)

1. Attach Main Beam SLT 225 (2) to the drophead.
2. Connect prop with drophead in the raised main beam. (Fig. 21)
3. Place prop in a vertical position.
4. Install panel (3).

The standard field is now complete. (Fig. 22)



Shuttering the casting segment

Set Pallet SD (5) with Panels down onto the forming area. Place panels from above in the main beams. Place empty pallets on the ground again, in preparation for the striking process. (Fig. 23)

1. Shutter the standard fields until there is no more space for the Main Beam SLT 225 or Compensation Beam SLT 150.
2. Form the infill areas. See A4.
3. Insert Cover Strip SAL (4).
4. Thinly spray the forming area with Release Agent – also from below if used for the first time.

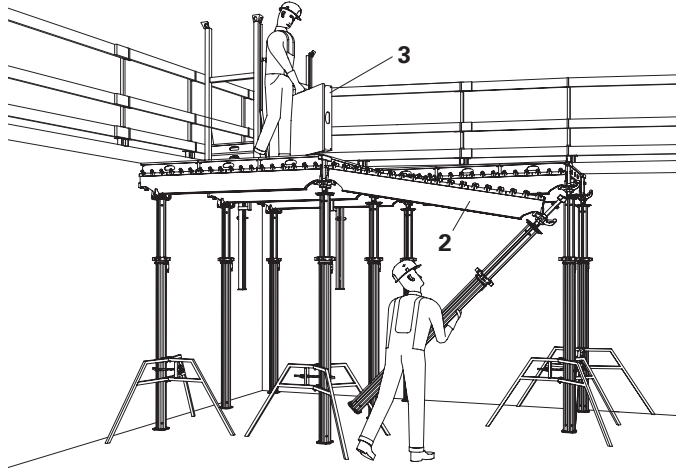

Fig. 21

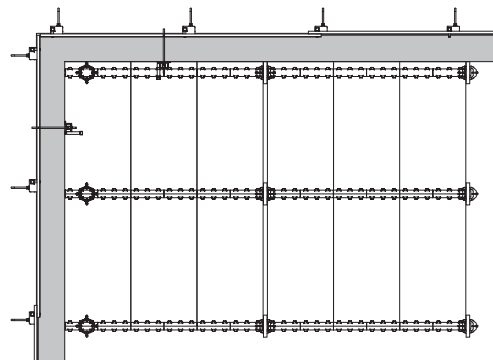

Fig. 22

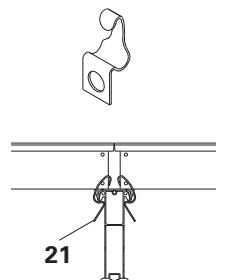

Fig. 22a

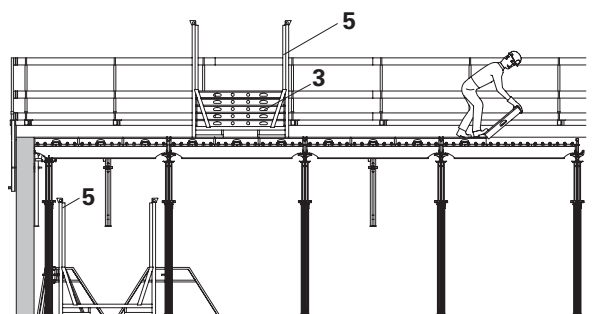
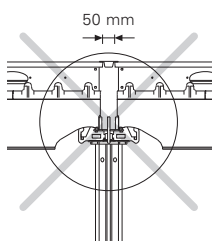

Fig. 23



The Prophead SSK is not a substitute for the Drophead with 5 cm spacings (cover strip).

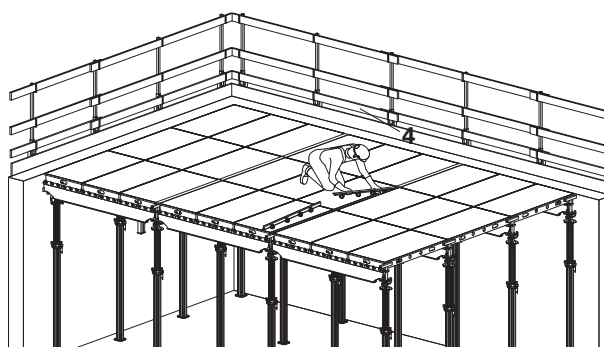

Fig. 24

A4 Infills

Longitudinal infills



Secure filler timbers with nails!

Drophead infills up to 2.25 m + 5 cm.

Prophead infills up to 2.25 m.

Infills are calculated based on length of room - $n \times 2.30 \text{ m}$ (2.25 m).

See Tables.

Forming the infills

1. Continue forming with prop, Compensation Beam SLT 150 (2.5) and Panel SDP (3) as in the standard field. (Fig. 25)

2. Gaps up to 75 cm are formed with:

- Prophead SSK (6) or
- Drophead SFK (1) and
- Combihead SCK (7)
- Edge Beam SRT (9)
- End Support SSL (10)
- Filler Timber SPH (11)
- square-shaped timbers (12) are securely nailed before elements are assembled.

21 mm formlining provided by the contractor, additional prop with crosshead and formwork girder (15). (Fig. 26 - 29)



Take into consideration the clamping direction of the formlining. See Tables Nail holes for fixing the timbers are available in the panel edge struts.



Tip for Fig. 27

Mount End Support SSL before beam assembly and swivel upwards together with the beam.

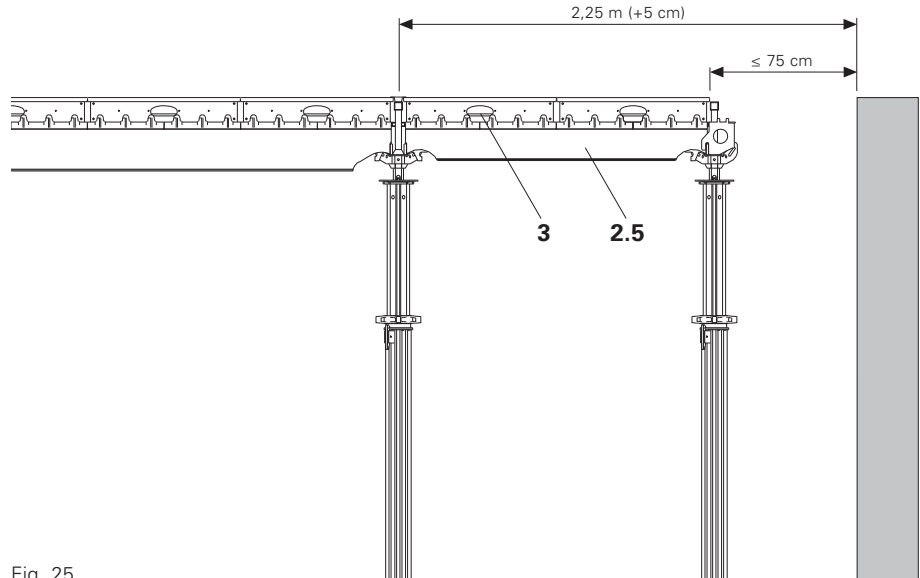

Fig. 25

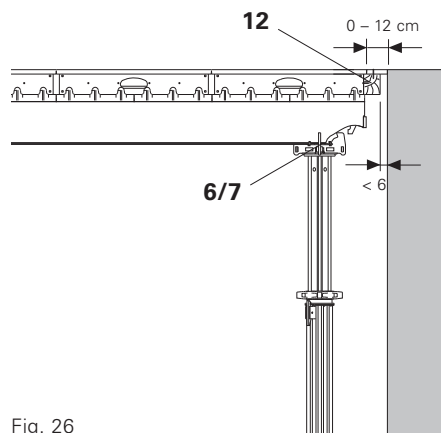

Fig. 26

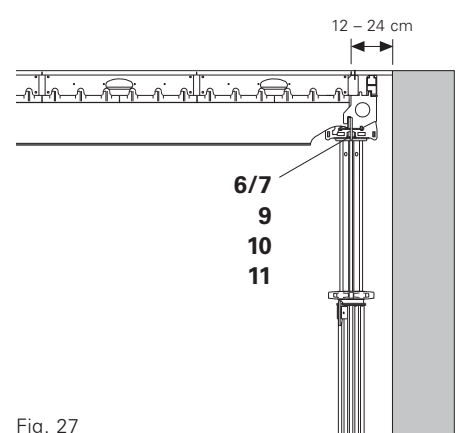

Fig. 27

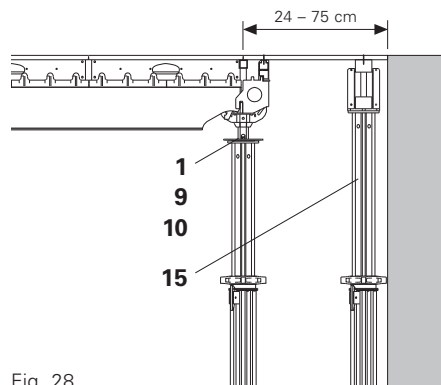

Fig. 28

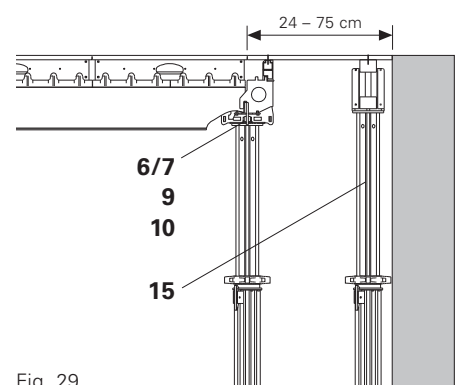

Fig. 29

A4 Infills

Transverse infills



Secure filler timbers with nails!

Max. infills are 1.50 m.
 Infills are calculated based on:
 length of room - n x 1.50 m.
 See Tables.

Forming the infills

1. Continue forming with prop, Main Beam SLT 225 (2) and Panel (3).
2. Install panel (3) crosswise. (Fig. 30a)
3. Gaps up to 75 cm are formed with:
 - Drophead SFK (1)
 - square-shaped timbers (12) are securely nailed before elements are assembled.
 - Edge Beam SRT (9) or
 - nail on Filler Timber SPH (11) before elements are assembled.
 - 21 mm formlining provided by the contractor, additional prop with cross-head and formwork girder (15). Panel Wedge Clip SPKK (20). (Fig. 31 - 33)



Take into consideration the clamping direction of the formlining. See Tables. Nail holes for fixing the timbers are available in the panel edge struts.

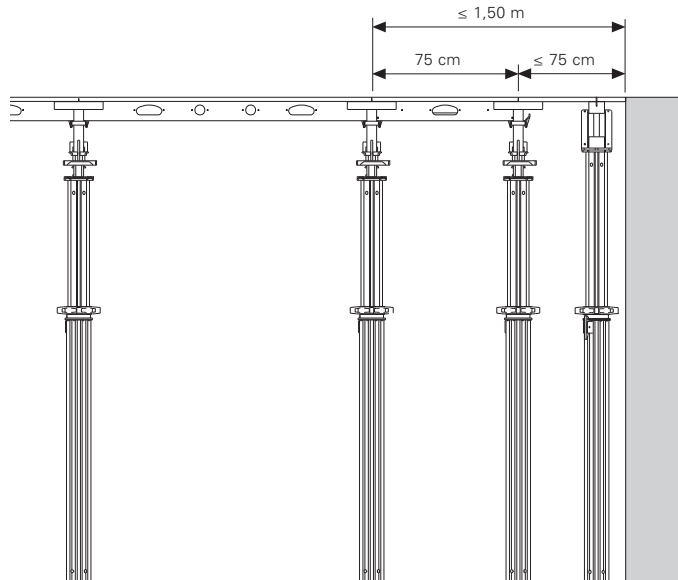

Fig. 30

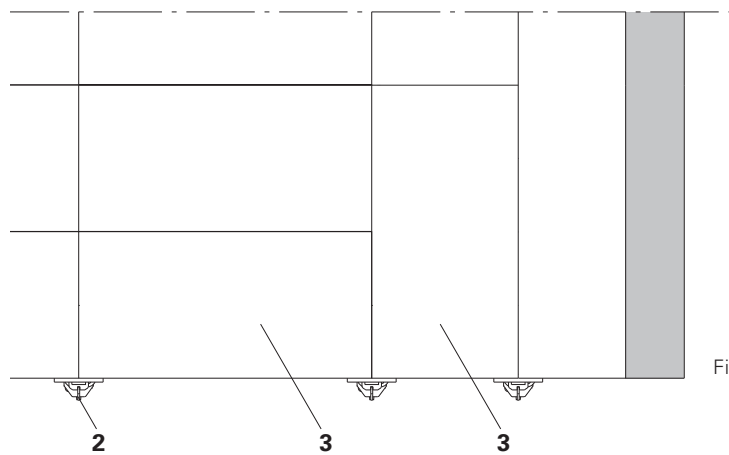

Fig. 30a

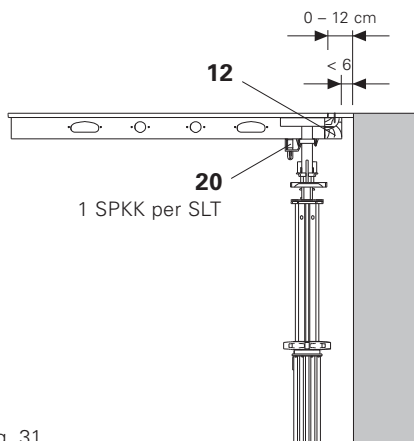

Fig. 31

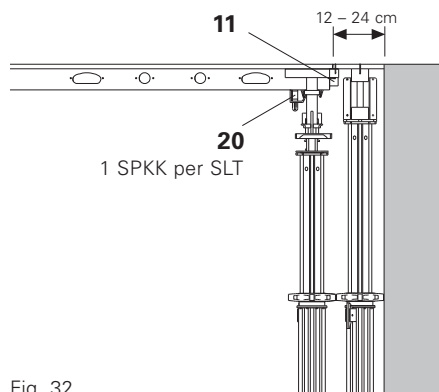

Fig. 32

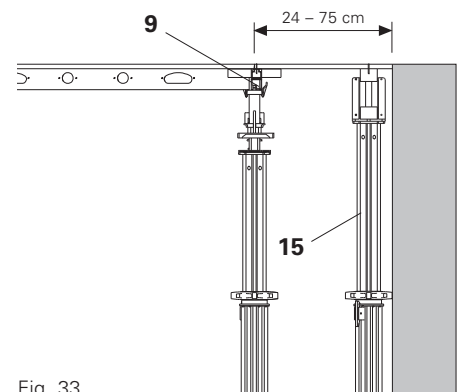

Fig. 33

A4 Infills

Edge Beam SRT 150, SRT 75



Secure filler plates with nails!

Installation

Install in a vertical position or turned by 180°.

The locking pin (9.1) secures the Edge Beam SRT (9)

a to the Main Beam SLT in a longitudinal direction.

b to the Prophead SSK in a transverse direction.

c in the End Support SSL (10) in a longitudinal direction.

d to the Combihead SCK (7) in a longitudinal and transverse direction.

(Fig. 34)

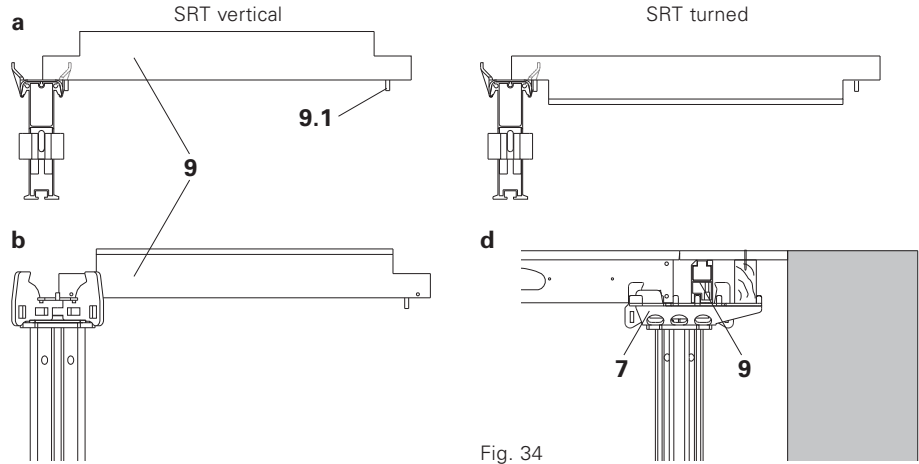

Fig. 34

End Support SSL

Use the End Support SSL as height adjustment for the transition from a standard field to an infill area.

(Fig. 35)

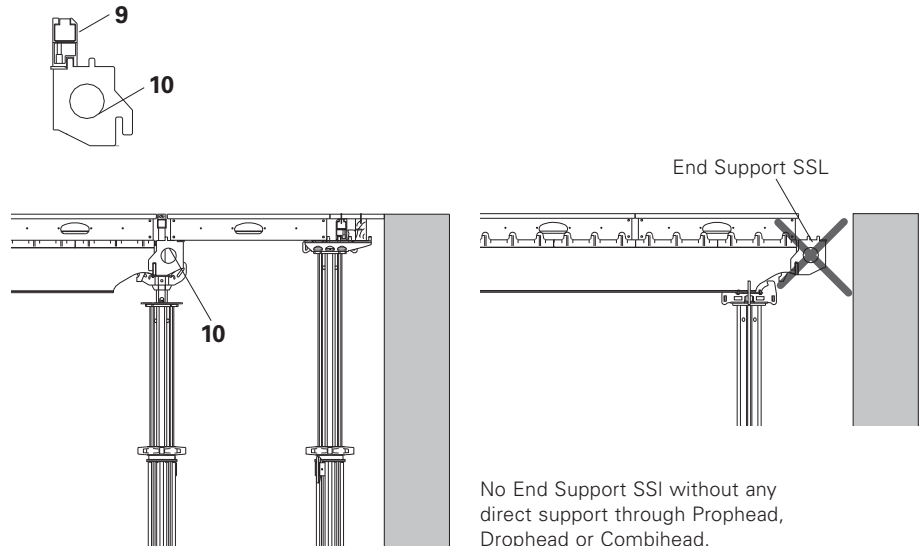

Fig. 35

Triangular Frame SDR 150/75, 75/75

Form infill areas with inclined walls using triangular frames.

Forming the infills

1. Continue forming as long as possible in the system.

2. Continue forming with infill panels and also inserted panels, as with the longitudinal and transverse infills.

3. Lay Triangular Frame (13) on the support (Main Beam Prophead or Combihead, End Support).

(Fig. 36)

4. Place support on the wall side and close the infill area with formlining provided by the contractor.

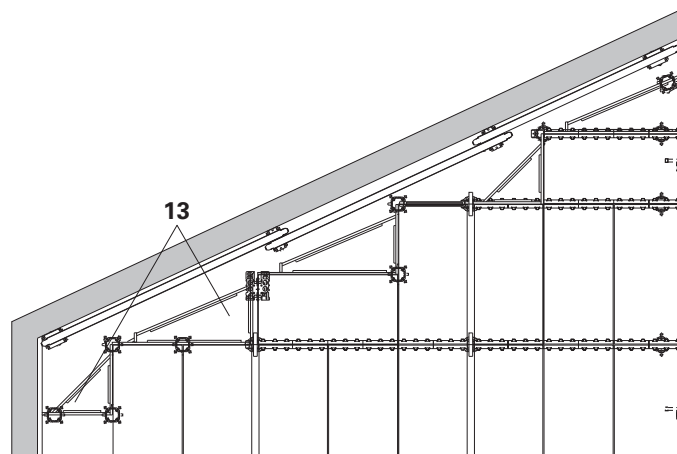

Fig. 36

A4 Infills

Combihead SCK

Use of longitudinal and transverse infills up to 25 cm.

The cantilever of the head plate is in longitudinal infills ≤ 19 cm, in transverse infills ≤ 12.5 cm.

The non-movable and non-twisting Combihead (7) is a secure support for:

- Main Beam SLT 225 (2),
- SLT 150 (2.5) (Fig. 37)
- Panel SDP (3) (Fig. 38)
- Edge Beam SRT (9) and Filler Timber SPH (11) or timber provided by the contractor with $b = 3.8 - 8$ cm and $h = 9.8$ cm (Fig. 39)
- End Support SSL (10) (Fig. 40)



Mounting the main beam

The Main Beam SLT must be mounted in the middle of the beam support of the SKYDECK heads. The Main Beam Connection (2.1) encloses the beam support of the head (7.1).

Exceptions

1. If the infill \leq the cantilever, then turn the head plate by 90° .
2. If used with the end support, then turn the head plate by 180° .
3. If the cantilever goes under the cover strip, then turn the head plate by 90° .

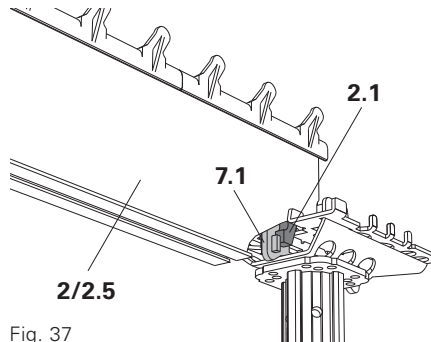

Fig. 37

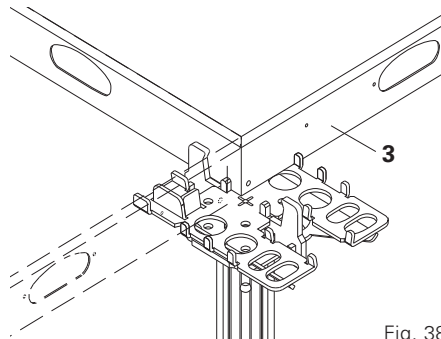
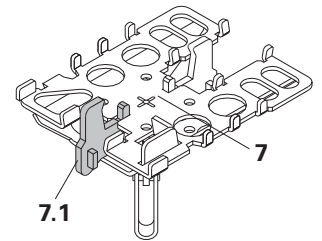

Fig. 38

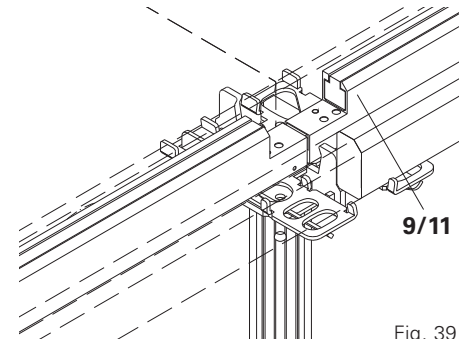

Fig. 39

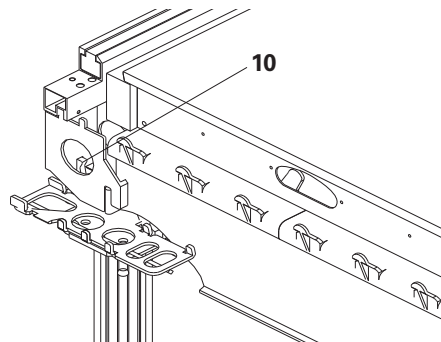

Fig. 40

Installation

The cantilever is pointing towards the wall. (Fig. 41)

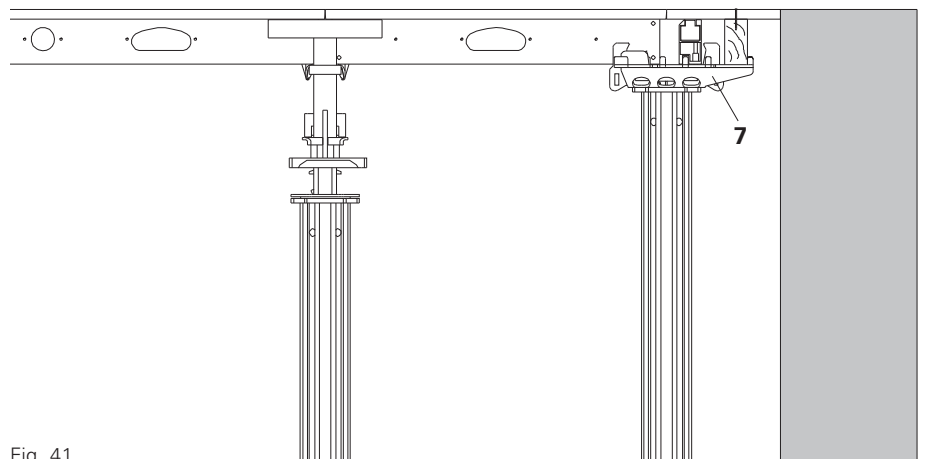

Fig. 41

A4 Infills

Longitudinal infills with Combihead SCK up to 1.50 m

(Fig. 42 - 47)



Secure filler plates with nails!
Filler Timber SPH for slab thicknesses up to 50 cm. Edge Beam SRT for slab thicknesses > 50 cm.

System components for longitudinal and transverse infills:

- Drophead SFK (1) or Prophead SSK (6)
- Combihead SCK (7)
- securely nail on square-shaped timber (12) before element assembly.
- Edge Beam SRT (9) or Filler Timber SPH (11)
- End Support SSL (10)
- 21 mm formlining supplied by the contractor, additional prop with cross-head and formwork girder (15)
- Panel Wedge Clip SPKK (20)

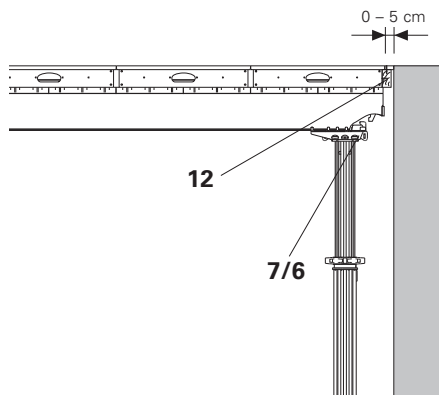

Fig. 42

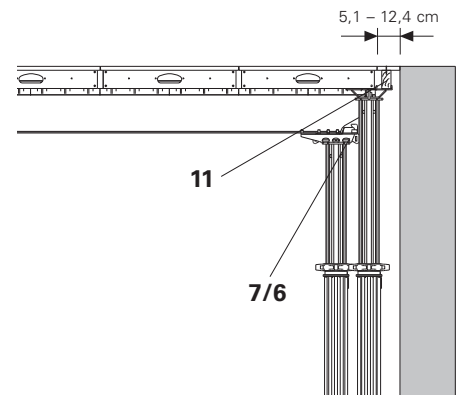

Fig. 43

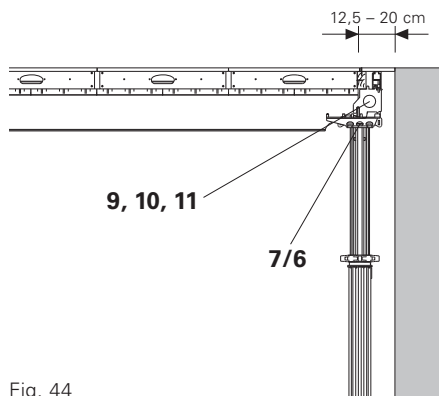

Fig. 44

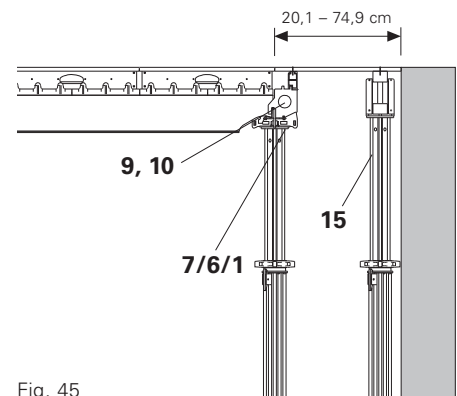

Fig. 45

** Use of Edge Beam and filler timber:

- | | |
|-----------------|--|
| 0 - 5 cm: | without |
| 5.1 - 12.4 cm: | 1 x Edge Beam SRT or Filler Timber SPH |
| 12.5 - 24.9 cm: | 1 x Edge Beam SRT + 1 x Filler Timber SPH or Edge Beam SRT |

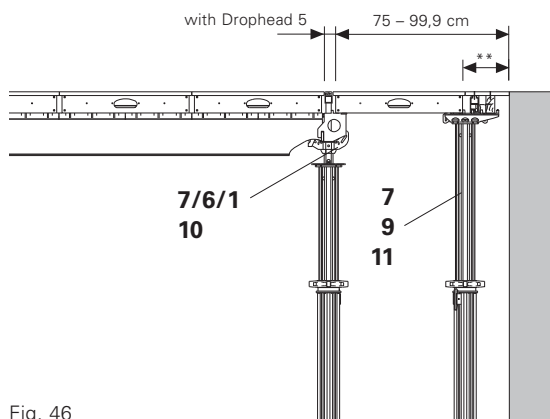

Fig. 46



Tip for Fig. 44
 Mount End Support before assembling the beam and then pivot upwards together with the beam.

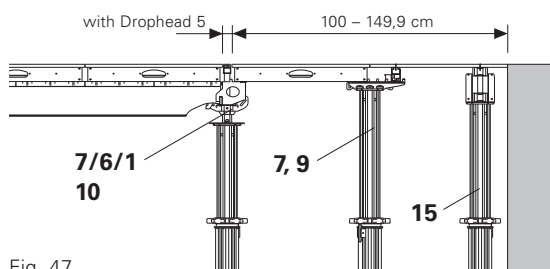

Fig. 47

A4 Infills

Transverse infill with Combihead SCK up to 1.50 m

(Fig. 48 - 53)



Secure filler plates with nails!
Filler Timber SPH for slab thicknesses up to 50 cm. Edge Beam SRT for slab thicknesses > 50 cm.

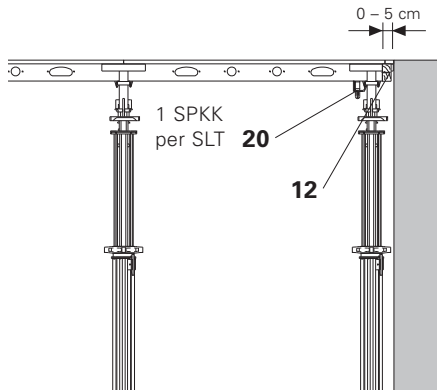

Fig. 48

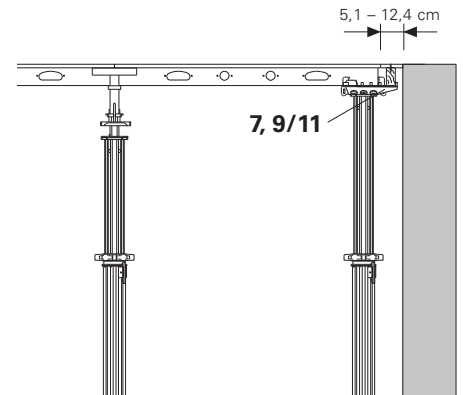

Fig. 49

** Use of Edge Beam and filler timber:

12.5 - 24 cm: 1 x Edge Beam SRT
 + 1 x Filler Timber SPH
 or Edge Beam SRT

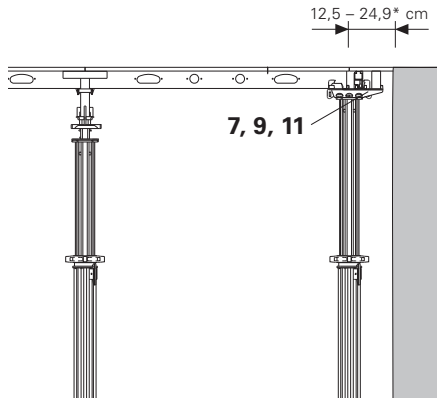

Fig. 50

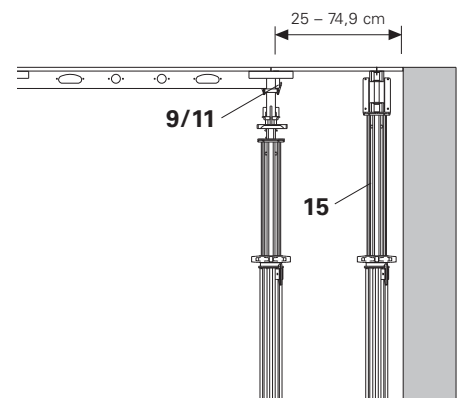

Fig. 51

** Use of Edge Beam and filler timber:

0 - 5 cm: without
 5.1 - 12.4 cm: 1 x Edge Beam SRT
 or Filler Timber SPH
 12.5 - 24.9 cm: 1 x Edge Beam SRT
 + 1 x Filler Timber SPH
 or Edge Beam SRT

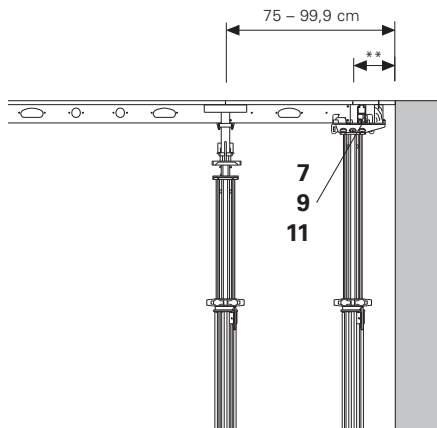

Fig. 52

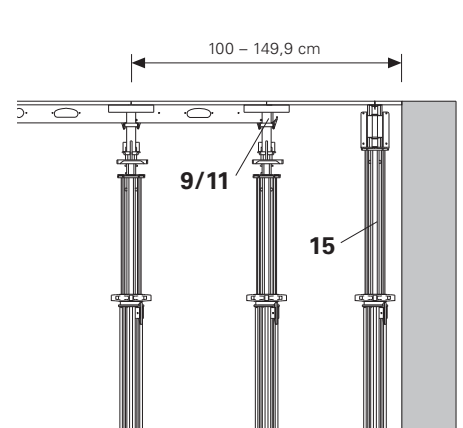

Fig. 53

A5 Shuttering around columns

1 recessed panel

Maximum column dimensions
 $x = 55 \text{ cm}$, $y = 138 \text{ cm}$.



Secure filler plates with nails!

Edge Beam SRT-2 150 (9a) or Filler Timber SPH 150 (11a).

During use, permissible loads must be observed (see Tables).



Observe the direction of span of the plywood.

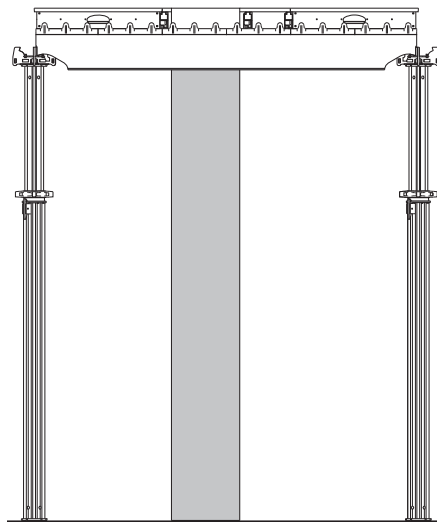
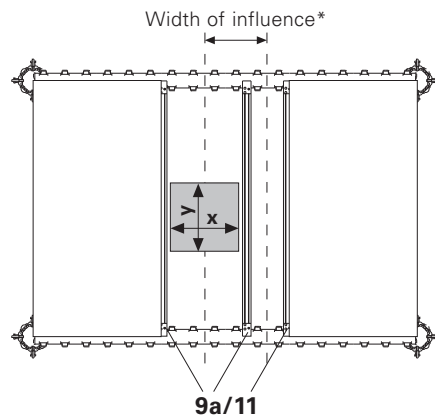

Fig. 54

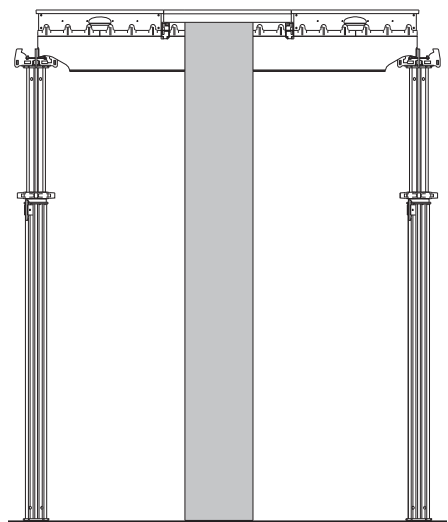

Fig. 55

Alternative:

Place filler timber or timber supplied by the contractor horizontally, $d = 49 \text{ mm}$ (11*).

Turn Edge Beam SRT 150-2 by 180° (9a*).

For formlining with 27 mm: $d = 47 \text{ mm}$.

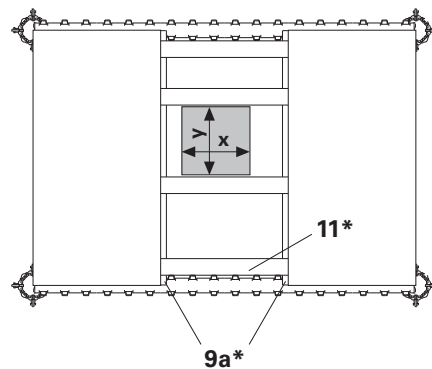

A5 Shuttering around columns

2 recessed panels

Maximum column dimensions
 $x = 65 \text{ cm}$, $y = 138 \text{ cm}$.



Secure filler plates with nails!

Turn Edge Beam SRT-2 75 by 180° (9b*).
 Turn Edge Beam SRT-2 150 (9a) or Filler
 Timber SPH 150 (11a) Edge Beam SRT-2
 150 by 180° (9a*).
 (Fig. 56)

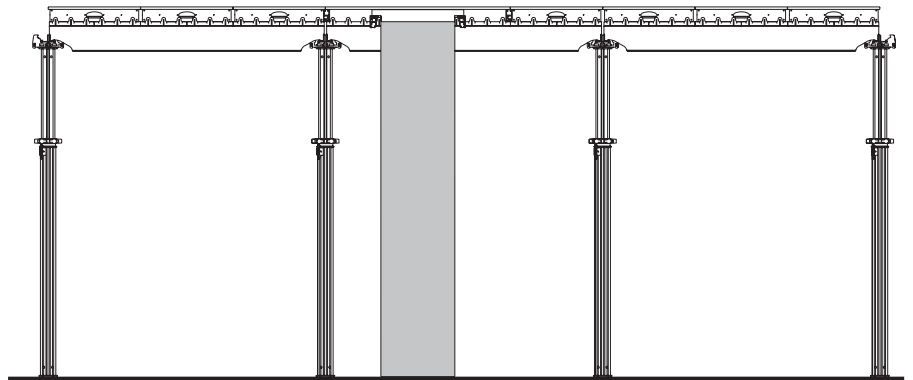
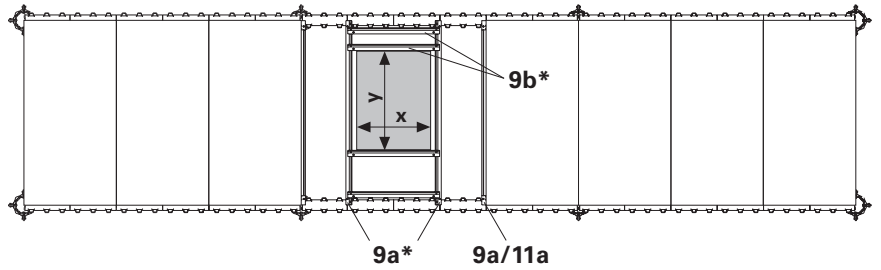

Fig. 56

Maximum column dimensions
 $x = 130 \text{ cm}$, $y = 138 \text{ cm}$.

With $y \geq 80 \text{ cm}$, the laterally-positioned
 filler plates are provided with additional
 support.

With smaller cross-sections, form infill
 areas with Panel 37.5.
 (Fig. 57)

Lay Filler Timber SPH 150 in a flat posi-
 tion (11a*).



Observe the direction of span of the
 plywood.

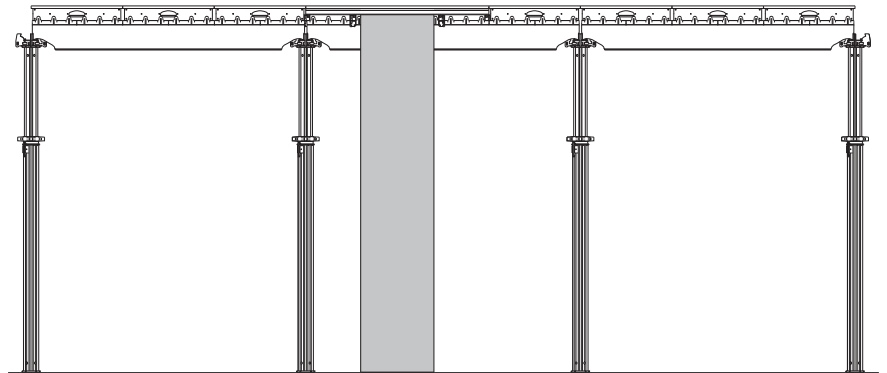
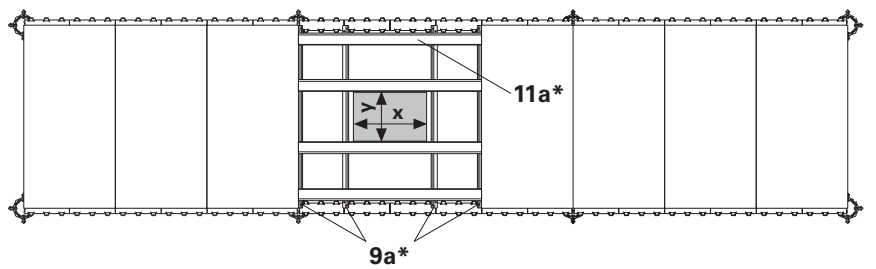

Fig. 57

A5 Shuttering around columns

3 recessed panels

Maximum column dimensions
 $x = 138 \text{ cm}$, $y = 142 \text{ cm}$.



Secure filler plates with nails!

Turn Edge Beam SRT-2 150 by 180° (9a*).

Edge Beam SRT-2 150 (9a) or Filler Timber SPH (11a). (Fig. 58)

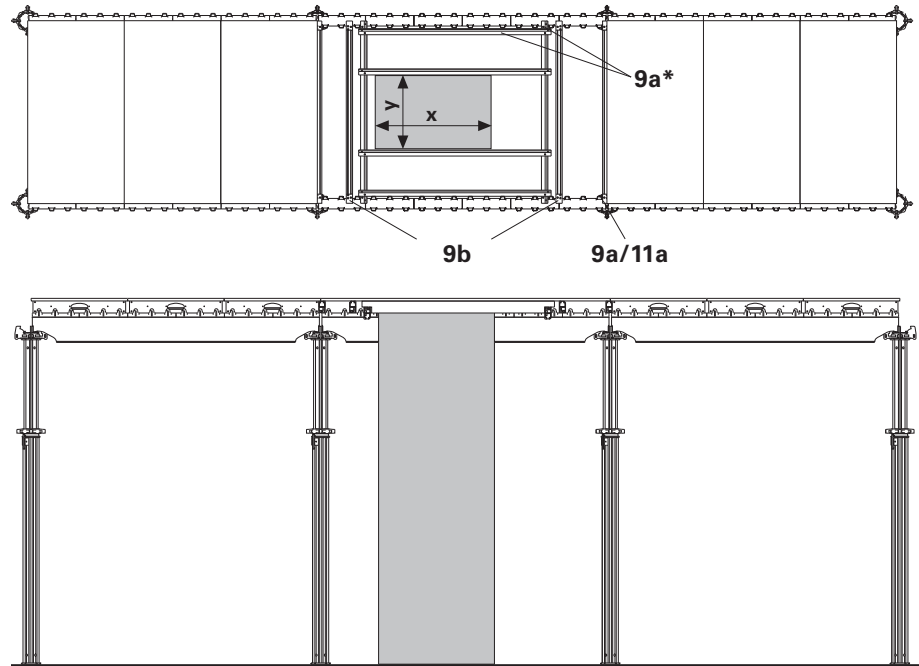

Fig. 58

Additional Edge Beam SRT-2 150 (9b) required with:

Slab thickness d [m]	Column side y [m]
$\leq 0,20$	no additional SRT
0,25	$\leq 0,60$
0,30	$\leq 0,80$
0,40	$\leq 1,15$

For other slab thicknesses, the values are interpolated linearly.



Observe the direction of span of the plywood.

A5 Shuttering around columns

Recessed main beams



Secure filler plates with nails!
****Secure Main Beam SLT props with tripods!**

Edge Beam SRT-2 150 (9a)
 Prophead SSK (6)
 End Support SSL (10)

Only used if moving the main beam axis is not required. (Fig. 59)

* additional formlining support depending on the situation.

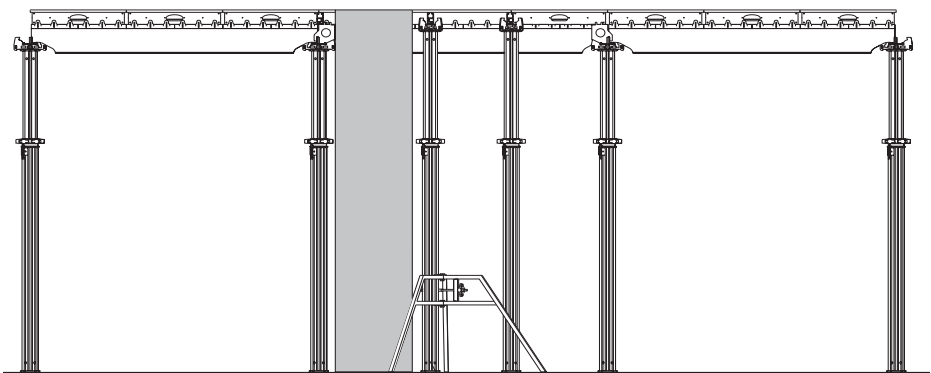
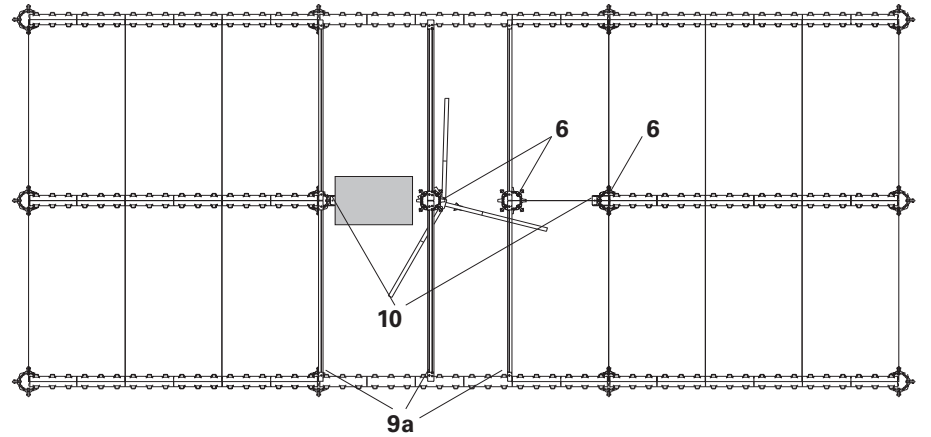

Fig. 59

Secure props by means of tripods.

Moving the main beam axis.
 (Fig. 60)



Observe the direction of span of the plywood.

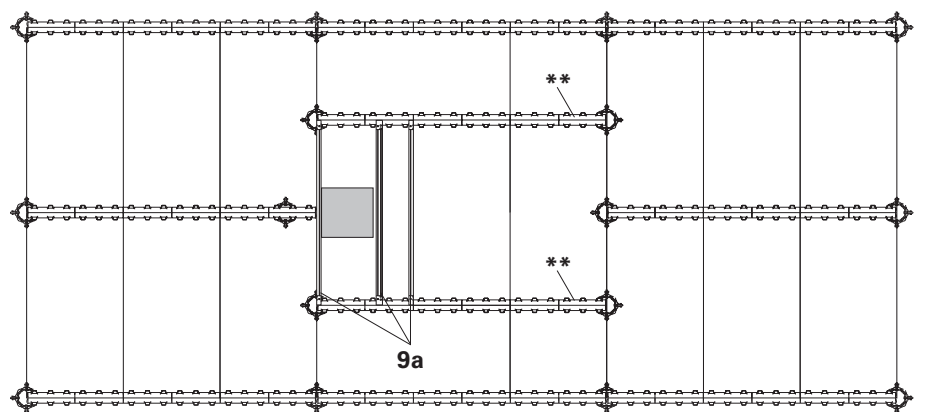

Fig. 60

A6 Guardrails

On open building edges

With SKYDECK Platforms SDB

- SDB 150 (16a)
 - SDB 225 (16b)
 - SDB 300 (16c)
- (Fig. 61)



Take into consideration assembly instructions SKYDECK Platform and instructions for use SKYDECK Transportation Fork!

The platform is a prefabricated foldable scaffold platform for use as work and safety scaffold according to DIN 4420. Load Class 2 classification, permissible load of 150 kg/m². It secures the open building edges of the SKYDECK slab formwork.



When using SKYDECK platforms, no safety scaffold is required for the levels below.

Bracing is carried out using the following components:

- Tension Sleeve SAO (22)
- Formwork Chain (23)
- Base Plate RS (24) (Item no. 028100) with appropriate fixing material with additional oblique tension force ≥ 3 kN (e.g. Hilti dowel HKD-S M12 x 50).

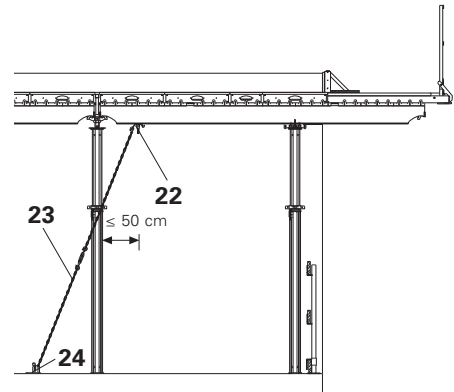

View from below: (Fig. 61a)

- End Support SSL (10)
- Timber supplied by contractor 70/40 x 700 mm (19)
- Panel Wedge Clip SPKK (20)

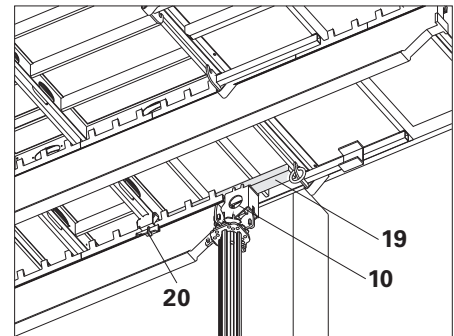

Fig. 61a

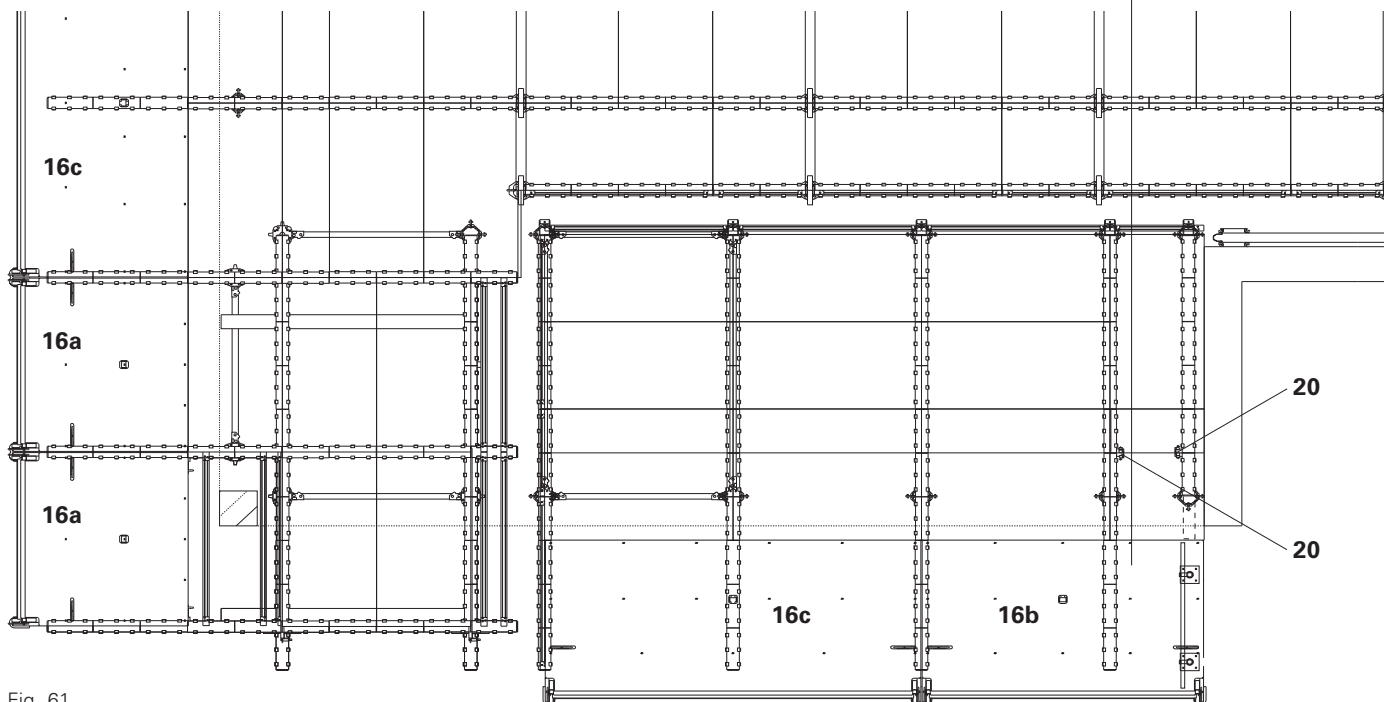

Fig. 61

A6 Guardrails

On a casting segment

With SKYDECK Guardrail Holder SGH and Guardrail post SGP

Assembly

1. Continuous mounting of guardrail holders (17) between the panels (spacing max. 1.55 m).
2. Mount on main beam after last panel.
3. Counter position the last outside guardrail holder (17.1).
- (Fig. 62a)
4. Insert guardrail posts (18).
5. Insert guardrail boards and secure by nailing. (Fig. 62)



For example: casting segment/stop end.

For ensuring the tightness of the panel joints, the panels on the last main beam can be secured with Panel Wedge Clips SPKK (20).

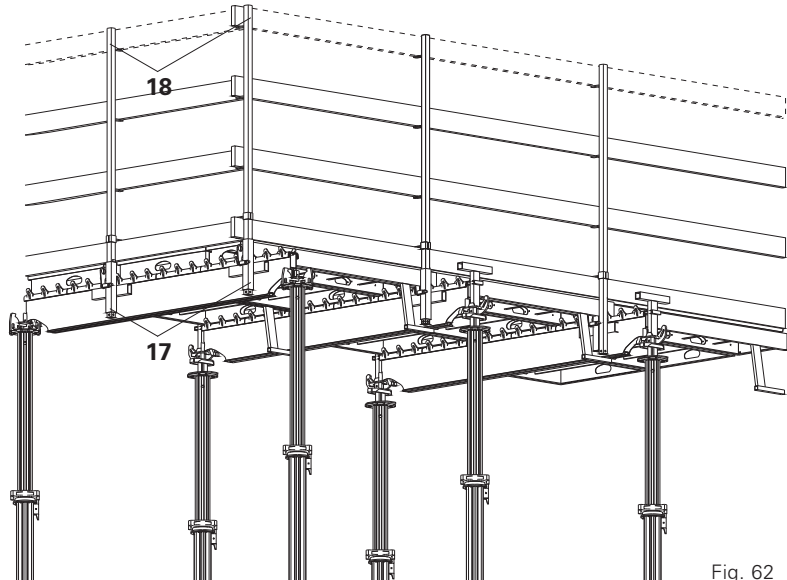

Fig. 62

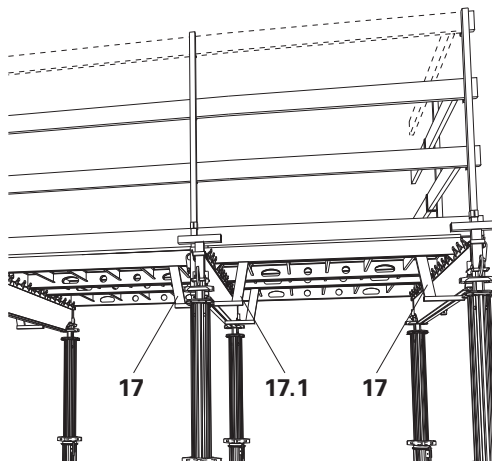
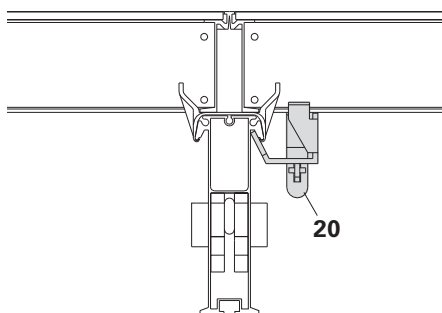

Fig. 62a

Panel Wedge Clip SPKK

Possible applications

1. Panel joint middle of main beam
Panel-panel connection



2. Overlapping panels
Panel-panel connection

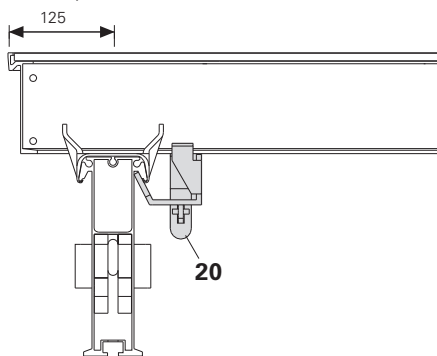

Side view

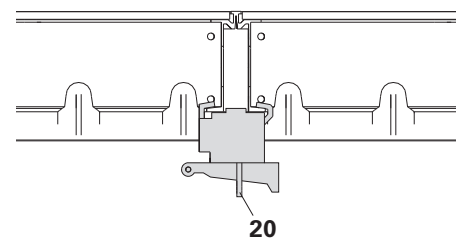

A7 Striking



Setting times: see Tables!
Keep access ways free!

Dismantling takes place from a safe and secure position, e.g. with PERI Stripping Cart ASW 465.

Lowering

- Lower droipheads over large area.
- Release wedge by means of hammer whilst paying attention to direction of wedge.

Between the panel and slab underside there is approx. 6 cm clearance. (Fig. 63)

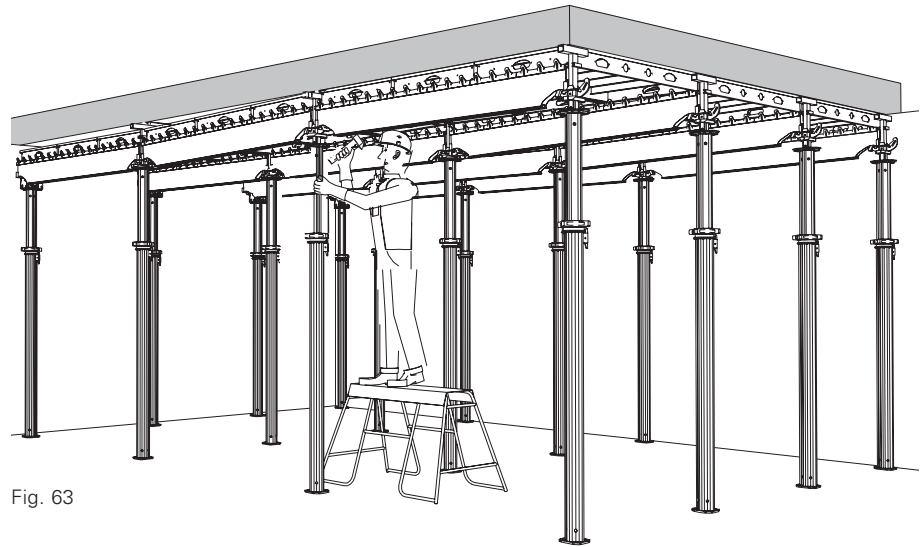

Fig. 63

Edge infills

Striking takes place firstly on the transverse infills and then the longitudinal infills.

- Remove props and store in pallets.
- Dismantle system supplements such as filler timbers, edge beams, end supports and combiheads, and store in pallets.
- Remove filler plates.

(Fig. 64)

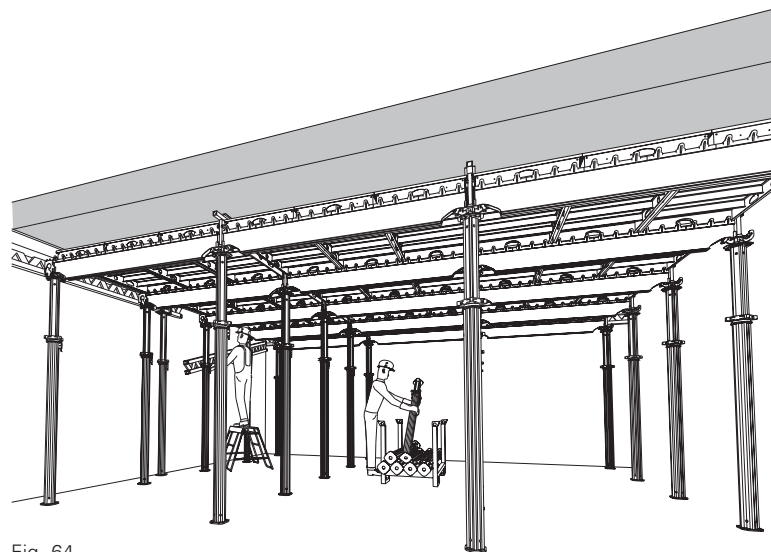

Fig. 64

A7 Striking

Panels

Always begin in the corner where both infills meet.

- Dismantle Panel SDP in one field after the other - begin with the middle panel.
 - Lift panel and push approx. 10 cm in the direction of the free side. Pivot downwards and store in pallet.
- (Fig. 65)

Main beam

- take down Main Beam SLT and store in pallet.
- (Fig. 66)

Only drophead props (1) with Cover Strips SAL (4) remain standing.

(Fig. 67)

Remaining areas

- Remove props on walls and store in pallets.
- Remove filler areas around in-situ columns.

After reaching the required concrete strength

- lower drophead props, remove props and store in pallets.
- Remove Cover Strips SAL (4).



With larger spans, begin in the middle with lowering and removal of the props.

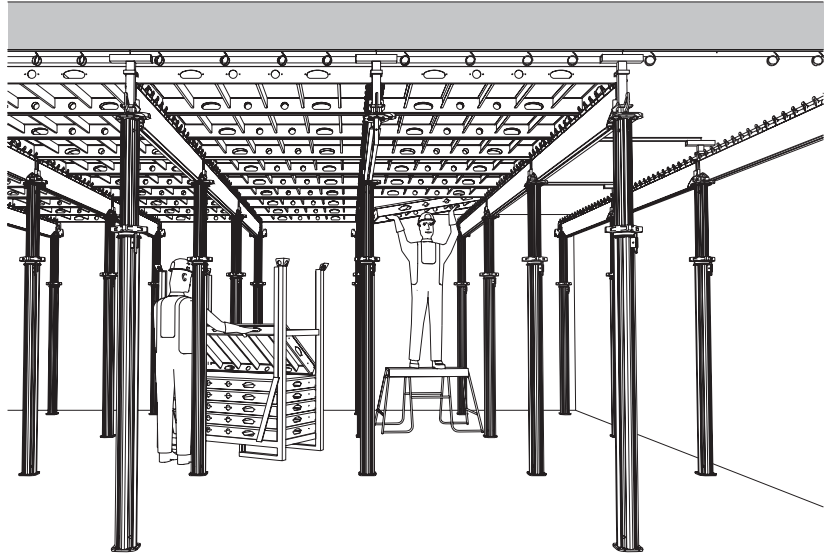

Fig. 65

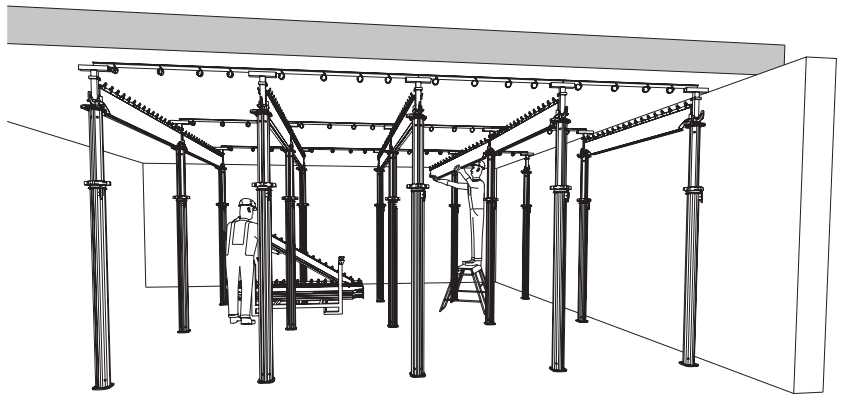

Fig. 66

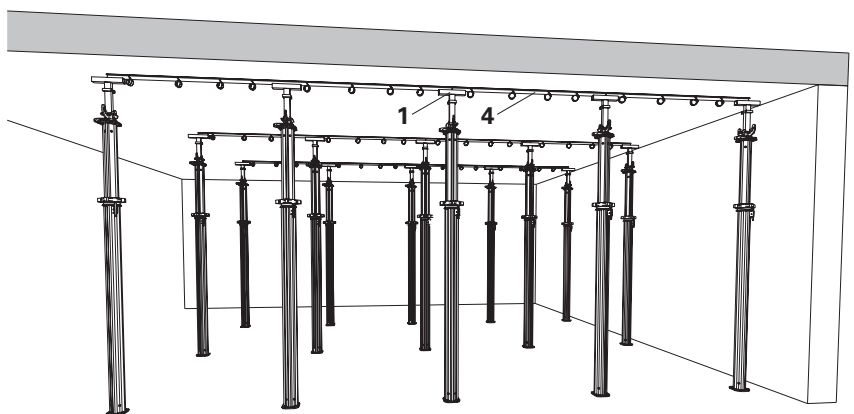

Fig. 67

Cleaning

Clean SKYDECK components before the next use and spray once again with PERI Bio Clean. See A8.

A8 Maintenance and cleaning

In order to maintain the value and operational readiness of the SKY-DECK slab formwork over a long time, ensure that the formwork is carefully handled at all times.

Maintenance tips

1. Concrete vibrator rubber end cap reduces the risk of damage to the formlining.
2. Spacers used for the reinforcement with large contact surfaces prevent impressions forming on the formlining.
3. When placing heavy items on the formlining, use support timbers in order to prevent any impressions on and damage to the formlining surface.
4. Spray the components with PERI Bio Clean before every use and clean the rear of the formwork with water immediately after concreting. (Fig. 70)
5. Spray moving parts, if required, with PERI Bio Clean.
6. For damage-free transportation, suitable PERI pallets and stacking devices are available. (Fig. 68)

Due to the powder coating, cleaning requirements are kept to a minimum. Panels and main beams are equipped with self-draining edges. They prevent the side areas from getting dirty and make cleaning easier. (Fig. 69)

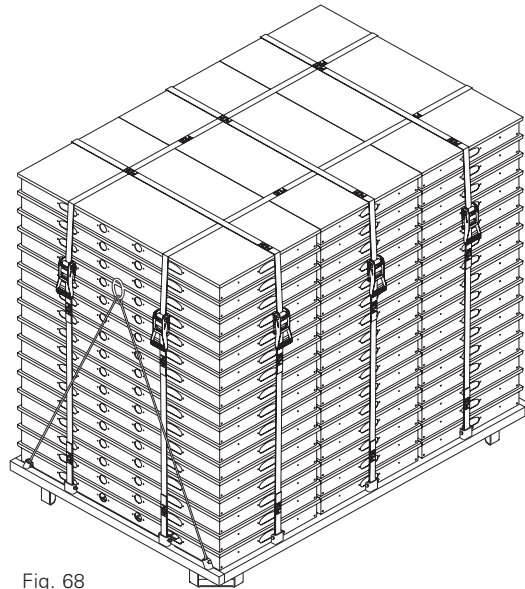

Fig. 68

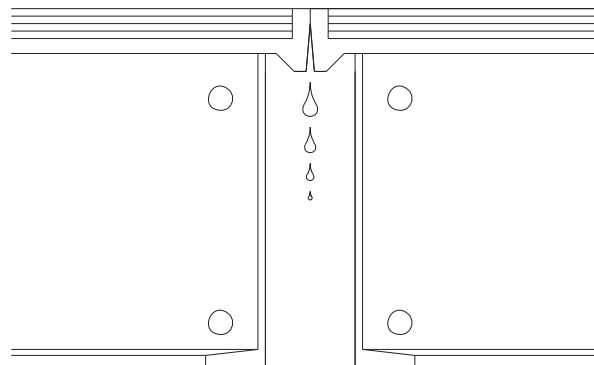

Fig. 69

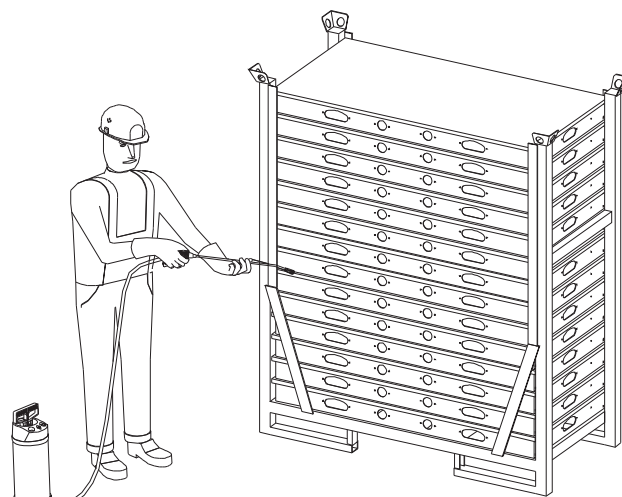
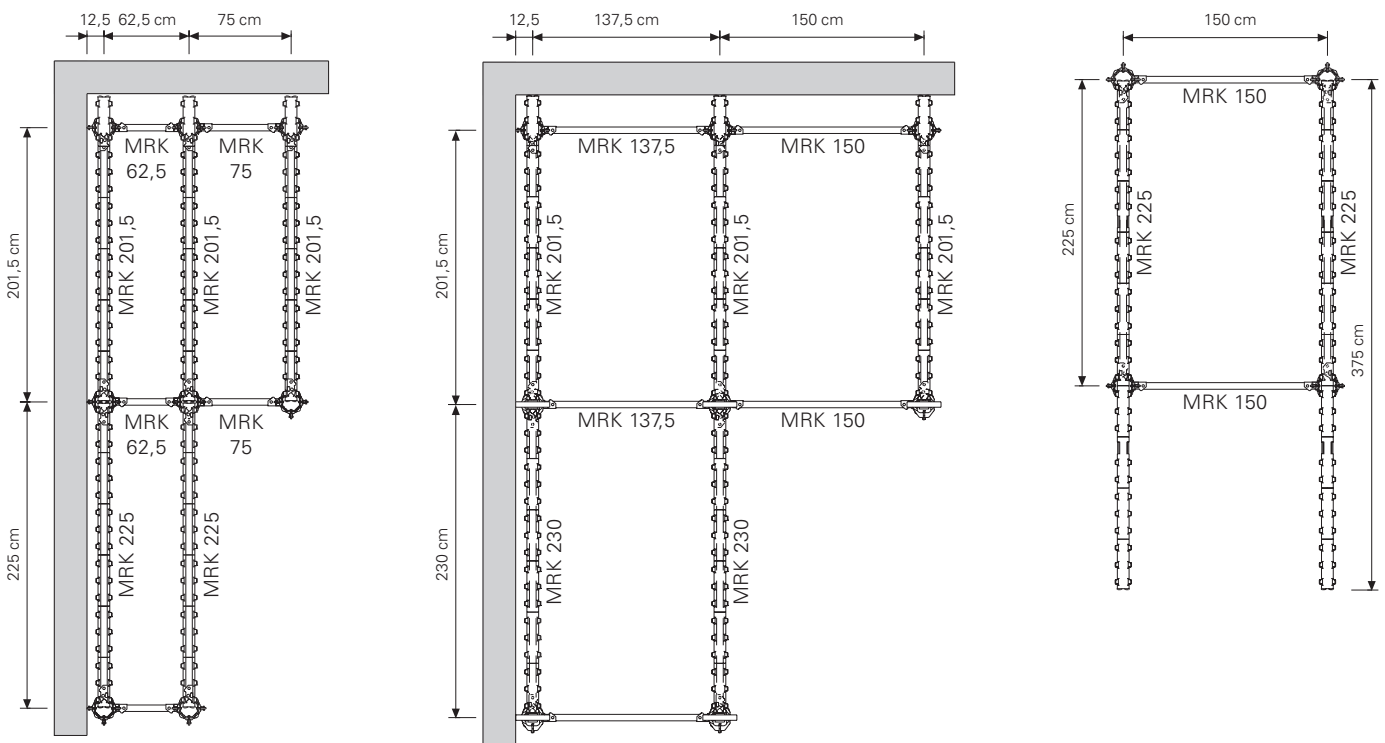

Fig. 70

A9 System dimensions

Overview of the required MRK Frames with the use of MULTIPROP towers

MRK Frame	Item no.	SKYDECK system
62.5 steel	028390	– Inset beam at wall beginning with 75 cm panel span. – Inset prop at wall beginning with combihead.
75 steel	028400	– Panel span 75 cm.
137.5 steel	028380	– Inset beam at wall beginning with 150 cm panel span.
150 steel	028350	– Panel span 150 cm.
201.5 alu	028460	– Inset prop at wall beginning under SLT 225 with prophead or combihead.
225 alu	028360	– SLT 225 prophead or combihead. – Use of Cantilever Beam SLT 375 on prophead/ combihead or corner tables.
230 alu	028470	– SLT 225 on dropheads.



A10 Site record

Company:

Corresponds to the requirements in accordance with DIN 4421.

Project:

This page is to be copied, filled out and filed in the daily construction records.

Unit:

This replaces the static proof according to DIN 4421 and the construction drawings for the ruled surface.	Slab thickness = cm Clear room height = m Prop length = m = clear room height - formwork assembly height (43 cm) (with drophead: 41 cm) Max. panel span = cm Selected prop = Available prop load (according to PERI Tables) = kN ≤ perm. prop load = kN (according to PERI Tables)
Check to be carried out on the construction site before concreting	Check whether above assumptions and/or specifications apply on the construction site Slab thickness = cm Max. panel span = cm Selected prop = Prop length = m All props in both axes in a vertical position? ≤ 1% <input type="checkbox"/> yes <input type="checkbox"/> Horizontal support for the formwork available in all directions? <input type="checkbox"/> yes <input type="checkbox"/> Mounted parts are obviously undamaged? <input type="checkbox"/> yes <input type="checkbox"/> Required bracing has been mounted? <input type="checkbox"/> yes <input type="checkbox"/>

Town _____ Date _____ Site manager (Signature) _____

SKYDECK Panel Slab Formwork

With Drophead SFK

Slab Thickness d [m]	Load q* [kN/m ²]	Main Beam SLT 225								Main Beam SLT 150							
		Panel Span c 1.50 m				Panel Span c 0.75 m				Panel Span c 1.50 m				Panel Span c 0.75 m			
		Prop Load [kN]		Deflection Line**		Prop Load [kN]		Deflection Line**		Prop Load [kN]		Deflection Line**		Prop Load [kN]		Deflection Line**	
			with centre support SSK		with centre support SSK		with centre support SSK		with centre support SSK		with centre support SSK		with centre support SSK		with centre support SSK		with centre support SSK
0.14	5.19	17.9		7		9.0		7		12.1		7					
0.16	5.71	19.7		7		9.8		7		13.3		7					
0.18	6.23	21.5		7		10.7		7		14.5		7					
0.20	6.75	23.3		7		11.6		7		15.7		7					
0.22	7.27	25.1		7		12.5		7		16.9		7					
0.24	7.79	26.9		7		13.4		7		18.1		7					
0.26	8.31	28.7		7		14.3		7		19.3		7					
0.28	8.83	30.5		7		15.2		7		20.5		7					
0.30	9.40	32.4	17.8	7	7	16.2		7		21.9		7					
0.35	10.94	37.7	20.8	6	7	18.9		7		25.4		7					
0.40	12.47	43.0	23.7	6	6	21.5		7		29.0		6					
0.45	14.01		26.6		6	24.2		7		32.6		6					
0.48	14.93		28.3		6	25.7		7		34.7		6					
0.50	15.54					26.8		7						18.1		7	
0.55	17.07					29.5		7						19.8		7	
0.60	18.61					32.1	19.3	7	7					21.6		7	
0.65	20.14					34.7	20.8	6	7					23.4		7	
0.70	21.68					37.4	22.4	6	7					25.2		7	
0.75	23.21					40.0	24.0	6	7					27.0		7	
0.80	24.74					42.7	25.6	6	7					28.8		7	
0.85	26.28						27.2		7					30.5		6	
0.90	27.81						28.8		7					32.3		6	
0.95	29.35						30.4		6					34.1		6	

*Load according to DIN 4421:

Dead load $g = 0.20 \text{ kN/m}^2$

Concrete load $b = 26 \text{ kN/m}^3 \times d \text{ (m)}$

Live load $p = 0.20 \times b$
 $1.5 \leq p \leq 5.0 \text{ kN/m}^2$

Total load $q = g + b + 0.9 \times p$

When calculating the prop load, the actual extension length may be used. The exact extension length of the prop when using the SKYDECK Drophead is: actual height **minus** 0.41 m. With a prop load of over **33.3 kN, bolting** on the Drophead (2 bolts M 12x40 mm Mu DIN 601) can only be omitted when using MULTIPROP props.

**Deflection according to DIN 18202, assuming perfect levelling.

With Prophead SSK

Slab Thickness d [m]	Load q* [kN/m²]	Main Beam SLT 225								Main Beam SLT 150							
		Panel Span c 1.50 m				Panel Span c 0.75 m				Panel Span c 1.50 m				Panel Span c 0.75 m			
		Prop Load [kN]		Deflection Line**		Prop Load [kN]		Deflection Line**		Prop Load [kN]		Deflection Line**		Prop Load [kN]		Deflection Line**	
			with centre support SSK		with centre support SSK		with centre support SSK		with centre support SSK		with centre support SSK		with centre support SSK		with centre support SSK		with centre support SSK
0.14	5.19	17.5		7		8.8		7		11.7		7					
0.16	5.71	19.3		7		9.6		7		12.8		7					
0.18	6.23	21.0		7		10.5		7		14.0		7					
0.20	6.75	22.8		7		11.4		7		15.2		7					
0.22	7.27	24.5		7		12.3		7		16.4		7					
0.24	7.79	26.3		7		13.1		7		17.5		7					
0.26	8.31	28.0		7		14.0		7		18.7		7					
0.28	8.83	29.8		7		14.9		7		19.9		7					
0.30	9.40	31.7	17.8	7	7	15.9		7		21.2		7					
0.35	10.94	36.9	20.7	6	7	18.5		7		24.6		7					
0.40	12.47	42.1	23.6	6	6	21.0		7		28.1		6					
0.45	14.01		26.5		6	23.6		7		31.5		6					
0.50	15.54		29.4		6	26.2		7		35.0		6					
0.51	15.85		30.0		6	26.7		7		35.7		6					
0.55	17.07					28.8		7						19.2		7	
0.60	18.61					31.4	19.2	7	7					20.9		7	
0.65	20.14					34.0	20.7	6	7					22.7		7	
0.70	21.68					36.6	22.3	6	7					24.4		7	
0.75	23.21					39.2	23.9	6	7					26.1		7	
0.80	24.74					41.8	25.5	6	7					27.8		7	
0.85	26.28						27.0		7					29.6		6	
0.90	27.81						28.6		7					31.3		6	
0.95	29.35						30.2		6					33.0		6	

***Load according to DIN 4421:**

Dead load $g = 0.20 \text{ kN/m}^2$

Concrete load $b = 26 \text{ kN/m}^3 \times d \text{ (m)}$

Live load $p = 0.20 \times b$
 $1.5 \leq p \leq 5.0 \text{ kN/m}^2$

Total load $q = g + b + 0.9 \times p$

When calculating the prop load, the actual extension length may be used. The exact extension length of the prop when using the SKYDECK Prophead is: actual height **minus** 0.33 m.

**Deflection according to DIN 18202, assuming perfect levelling.

Panel System, Striking Time Guidelines

Panel System

Slab Thickness d [m]	Load q* [kN/m ²]	Prop Load [kN]	** Tolerances to DIN 18202, Line
0,14	5,19	5,8	7
0,16	5,71	6,4	7
0,18	6,23	7,0	7
0,20	6,75	7,6	7
0,22	7,27	8,2	7
0,24	7,79	8,8	7
0,26	8,31	9,3	7
0,28	8,83	9,9	7
0,30	9,40	10,6	7
0,35	10,94	12,3	7
0,40	12,47	14,0	6
0,45	14,01	15,8	6
0,48	14,93	16,8	6
0,50	15,54	17,5	6
0,51	15,85	17,8	6

*Load according to DIN 4421:

Dead load $g = 0,20 \text{ kN/m}^2$

Concrete load $b = 26 \text{ kN/m}^3 \times d \text{ (m)}$

Live load $p = 0,20 \times b$
 $1,5 \leq p \leq 5,0 \text{ kN/m}^2$

Total load $q = g + b + 0,9 \times p$

** Tolerances to DIN 18202.
 Assuming perfect levelling.

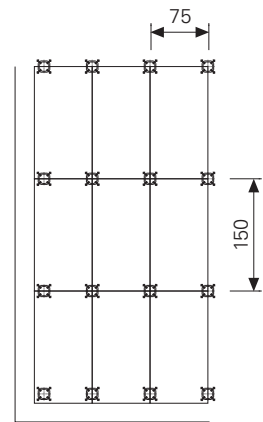

Striking Time Guidelines* [Days] for Drophead System.

Slab Thickness d [m]	Required Concrete Strength f_{ck} [N/mm ²]	*Guide values for striking time [days] for Panels and Main Beams at average curing temperature [°C] of		
		5°	10°	20°
0,14	15	10	6	5
0,16	13	8	5	4
0,18	11	6	4	3
0,20	9	5	3	2
0,22	8	4	3	2
0,25	7	4	2	2
0,30	6	3	2	2
0,35	5	3	2	1
0,40–0,95	5	2	1	1

The necessary concrete strength at the time of striking is decisive. This is to be calculated by suitable methods.

Account must also be taken of DIN 1045, e.g. curing.

At least $1.31 \text{ cm}^2/\text{m}$ (Q 131) is necessary for the bottom reinforcement layer.

For systems without centre support of the main beams.

A live load of 1 kN/m^2 is taken into account for the early struck slab.

*Guide values according to Leonhard for cement Z 35, CEM I 32.5 R.

Fillers, forming around columns

Perm. Width B [m] of the Filler

Slab Thickness d [m]	Case 1	Case 2
	Fin-Ply 21 mm Spruce 21 mm Beto 21 mm	Fin-Ply 21 mm Spruce 21 mm Beto 21 mm
0,14	0,77	0,85
0,16	0,75	0,82
0,18	0,72	0,80
0,20	0,70	0,78
0,22	0,69	0,76
0,24	0,67	0,75
0,26	0,66	0,73
0,28	0,64	0,72
0,30	0,63	0,71
0,35	0,61	0,69
0,40	0,59	0,67
0,45	0,57	0,65
0,50	0,56	0,64
0,51	0,55	0,63
0,55	0,53	0,62
0,60	0,51	0,60
0,65	0,50	0,59
0,70	0,49	0,58
0,75	0,48	0,57
0,80	0,47	0,56
0,85	0,46	0,55
0,90	0,45	0,54
0,95	0,44	0,53

Note:
Deflection single span beam B/300.

Perm. width of influence E_B [m] when forming around columns

Slab Thickness d [m]	Panel 150 L/500 = 30 mm		Panel 75 L/500 = 15 mm	
	SRT-2	SPH	SRT-2	SPH
0,14	1,08	0,38		
0,16	0,95	0,33		
0,18	0,85	0,30		
0,20	0,77	0,27		
0,22	0,70	0,25		
0,24	0,64	0,23		
0,26	0,60	0,21		
0,28	0,55	0,19		
0,30	0,52	0,18		
0,35	0,45	0,16		
0,40	0,39	0,14	1,71	0,51
0,45	0,35	0,12	1,52	0,46
0,48	0,33	0,11	1,43	0,43
0,50	0,31	0,11	1,37	0,41
0,55			1,25	0,37
0,60			1,15	0,34
0,65			1,06	0,32
0,70			0,98	0,30
0,75			0,92	0,28
0,80			0,86	0,26
0,85			0,81	0,24
0,90			0,77	0,23
0,95			0,73	0,22

Case 1

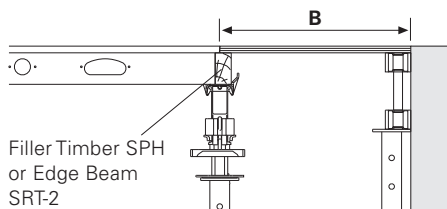

Case 2

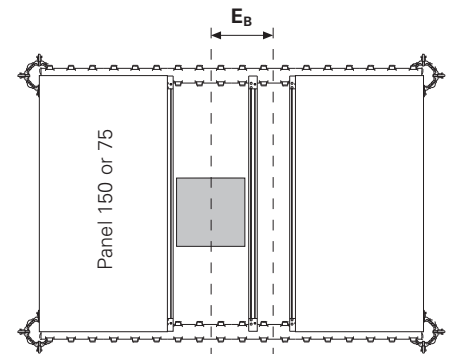
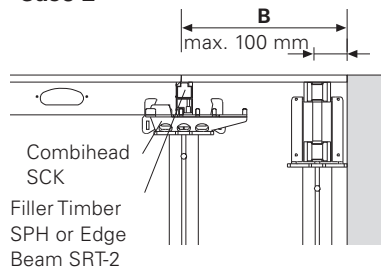

Perm. Span L [m] of the Edge Main Girders

Girders used	Slab Thickness [m]						
	0,20	0,30	0,40	0,50	0,60	0,70	0,80
GT 24	3,51	3,15	2,88	2,68	2,52	2,40	2,29
VT 20	2,85	2,56	2,34	2,18	2,05	1,91	1,67
KH 10/16	2,64	2,37	2,17	2,02	1,90	1,81	1,73

Width of influence for 40 cm plywood

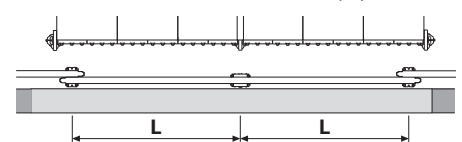

Permissible Prop Load [kN] according to the Type Test

Extension Length [m]	PEP 20 N 260* L = 1.51 – 2.60 m		PEP 20 – 300 PEP 20 N 300* L = 1.71 – 3.00 m		PEP 20 – 350 PEP 20 N 350* L = 1.96 – 3.50 m		PEP 20 – 400 PEP 20 G 410* L = 2.21 – 4.00 m		PEP 20 – 500 L = 2.71 – 5.00	
	Outer Tube Bottom	Inner Tube Bottom	Outer Tube Bottom	Inner Tube Bottom	Outer Tube Bottom	Inner Tube Bottom	Outer Tube Bottom	Inner Tube Bottom	Outer Tube Bottom	Inner Tube Bottom
1.60	35.0	35.0								
1.70	35.0	35.0								
1.80	35.0	35.0	35.0	35.0						
1.90	35.0	35.0	35.0	35.0						
2.00	33.5	35.0	35.0	35.0	35.0	35.0				
2.10	31.9	35.0	32.2	35.0	35.0	35.0				
2.20	30.9	35.0	30.5	35.0	35.0	35.0				
2.30	29.8	35.0	29.0	35.0	35.0	35.0	35.0	35.0		
2.40	28.6	35.0	27.8	35.0	35.0	35.0	35.0	35.0		
2.50	27.1	32.9	26.9	35.0	35.0	35.0	35.0	35.0		
2.60	24.8	29.4	26.1	35.0	33.8	35.0	35.0	35.0		
2.70			24.9	31.7	32.4	35.0	35.0	35.0		
2.80			23.3	28.5	31.2	35.0	35.0	35.0	35.0	35.0
2.90			21.6	25.7	30.2	35.0	35.0	35.0	35.0	35.0
3.00			20.0	23.2	29.2	35.0	35.0	35.0	35.0	35.0
3.10					27.5	34.6	33.6	35.0	35.0	35.0
3.20					25.7	31.5	32.5	35.0	35.0	35.0
3.30					24.1	28.8	31.2	35.0	35.0	35.0
3.40					22.4	26.4	29.6	35.0	35.0	35.0
3.50					20.7	24.1	27.8	33.9	35.0	35.0
3.60							26.1	31.2	35.0	35.0
3.70							24.5	28.9	35.0	35.0
3.80							23.0	26.8	35.0	35.0
3.90							21.6	24.8	35.0	35.0
4.00							20.1	22.8	34.2	35.0
4.10									32.3	35.0
4.20									30.6	35.0
4.30									28.9	34.0
4.40									27.4	31.9
4.50									26.0	29.9
4.60									24.6	28.1
4.70									23.4	26.4
4.80									22.1	24.9
4.90									20.9	23.4
5.00									20.0	21.8

All PEP 20 Props conform with DIN EN 1065 class D with a permissible load for the entire extension range of minimum 20 kN.

All PEP 20 Props clamped in the Table Swivel Head or UNIportal Head fitted to PERI tableforms have a permissible load of minimum 30 kN over the entire extension range.

*For the N and G Props the application Inner Tube at Bottom is only possible with PERI Slab Tables or SKYDECK (bolted head).

PEP 30

Permissible Prop Load [kN] according to the Type Test

Extension Length [m]	PEP 30 – 150		PEP 30 – 250		PEP 30 – 300		PEP 30 – 350		PEP 30 – 400	
	L = 0.96 – 1.50 m		L = 1.46 – 2.50 m		PEP 30 G 300* L = 1.71 – 3.00 m		PEP 30 G 350* L = 1.96 – 3.50 m		L = 2.21 – 4.00 m	
	Outer Tube Bottom	Inner Tube Bottom	Outer Tube Bottom	Inner Tube Bottom	Outer Tube Bottom	Inner Tube Bottom	Outer Tube Bottom	Inner Tube Bottom	Outer Tube Bottom	Inner Tube Bottom
1.00	35.0	35.0								
1.10	35.0	35.0								
1.20	35.0	35.0								
1.30	34.9	35.0								
1.40	34.2	35.0								
1.50	33.5	35.0	40.0	40.0						
1.60			40.0	40.0						
1.70			40.0	40.0						
1.80			40.0	40.0	40.0	40.0				
1.90			38.5	40.0	40.0	40.0				
2.00			36.8	40.0	40.0	40.0	40.0	40.0		
2.10			35.3	40.0	40.0	40.0	40.0	40.0		
2.20			34.4	40.0	40.0	40.0	40.0	40.0		
2.30			33.3	40.0	40.0	40.0	40.0	40.0	40.0	40.0
2.40			32.1	37.6	40.0	40.0	40.0	40.0	40.0	40.0
2.50			30.1	34.8	39.9	40.0	40.0	40.0	40.0	40.0
2.60					38.8	40.0	40.0	40.0	40.0	40.0
2.70					37.4	40.0	40.0	40.0	40.0	40.0
2.80					35.8	40.0	40.0	40.0	40.0	40.0
2.90					33.2	37.2	40.0	40.0	40.0	40.0
3.00					30.4	33.8	40.0	40.0	40.0	40.0
3.10							40.0	40.0	40.0	40.0
3.20							37.6	40.0	40.0	40.0
3.30							35.0	37.6	40.0	40.0
3.40							32.3	34.6	40.0	40.0
3.50							30.0	31.6	40.0	40.0
3.60									40.0	40.0
3.70									40.0	40.0
3.80									37.4	40.0
3.90									34.8	37.0
4.00									32.2	33.9

All PEP 30 Props conform with DIN EN 1065 class E with a permissible load for the entire extension range of minimum 30 kN.

All PEP 30 Props clamped in the Table Swivel Head or UNIPORTAL Head fitted to PERI tableforms have a permissible load of minimum 40 kN (PEP 30-150 = 35 kN) over the entire extension range.

*For the N and G Props the application Inner Tube at Bottom is only possible with PERI Slab Tables or SKYDECK (bolted head).

SKYDECK Panel Slab Formwork

MULTIPROP 250, 350, 480, 625

Permissible Prop Load [kN] according to the Type Test

Extension Length [m]	MP 250 L = 1.45 – 2.50 m		MP 350 L = 1.95 – 3.50 m		MP 480 L = 2.60 – 4.80 m		MP 625 L = 4.30 – 6.25 m		
	Outer Tube Bottom	Inner Tube Bottom	Outer Tube Bottom	Inner Tube Bottom	Outer Tube Bottom	Inner Tube Bottom	Outer Tube Bottom	Inner Tube Bottom	
1.45	73.3	76.2							
1.50	73.3	76.2							
1.60	73.3	76.2							
1.70	73.3	76.2							
1.80	71.7	76.2							
1.90	68.6	76.2							
1.95	67.0	76.2	88.3	87.4					
2.00	65.4	76.2	88.3	87.4					
2.10	63.8	74.6	83.0	87.4					
2.20	62.2	73.0	77.7	87.4					
2.30	61.1	70.5	72.9	86.6					
2.40	60.6	67.0	68.6	85.1					
2.50	60.0	63.6	64.4	83.5					
2.60			61.9	80.7	85.9	71.4			
2.70			59.3	77.8	81.2	71.1			
2.80			57.5	74.9	76.5	70.8			
2.90			55.7	71.9	71.8	70.4			
3.00			54.3	68.3	67.1	70.1			
3.10			52.9	64.6	63.0	69.4			
3.20			51.4	60.0	58.9	68.6			
3.30			49.8	55.4	54.8	67.9			
3.40			46.4	50.3	52.5	66.2			
3.50			42.9	45.1	50.2	64.5			
3.60					47.9	62.8			
3.70					46.0	58.6			
3.80					44.2	54.4			
3.90					42.3	50.2			
4.00					40.4	46.9			
4.10					38.5	43.7			
4.20					36.6	40.4			
4.30					34.8	38.2	56.2	44.6	
4.40					32.9	36.0	54.7	44.6	
4.50					31.1	33.7	53.1	44.6	
4.60					29.3	31.5	50.9	43.8	
4.70					27.4	29.3	48.8	43.0	
4.80					25.6	27.1	46.4	42.1	
4.90							43.8	41.2	
5.00							41.2	40.3	
5.10	MULTIPROPS are classified according to official approval as follows: MP 250 = Class T 25 MP 480 = Class D 45 MP 350 = Class R 35 MP 625 = Class D 60 Note: We recommend using the HD Wingnut Spanner, Item no. 022027, to release the loads > 60 kN. MULTIPROP 350 and 480 clamped in the Table Swivel Head or UNIPORTAL Head fitted to PERI tableforms have a permissible load of minimum 56 kN for the MP 350, and minimum of 36 kN for the MP 480 over the entire extension range.							38.6	38.8
5.20								36.1	37.3
5.30								33.8	35.9
5.40								31.9	34.5
5.50								29.9	33.1
5.60								28.4	31.6
5.70								26.9	30.1
5.80								25.5	28.6
5.90								24.3	27.0
6.00								23.1	25.4
6.10								22.0	24.1
6.20								20.9	22.8
6.25	20.4	22.1							

Item no.	Weight kg		L	B
		Panel SDP		
061000	15,500	Panel SDP 150 x 75	1500	750
061011	11,700	Panel SDP 150 x 50	1500	500
061020	9,780	Panel SDP 150 x 37.5	1500	375
061010	8,560	Panel SDP 75 x 75	750	750
061013	6,350	Panel SDP 75 x 50	750	500
061030	5,250	Panel SDP 75 x 37.5	750	375

Panel with 9 mm formlining.

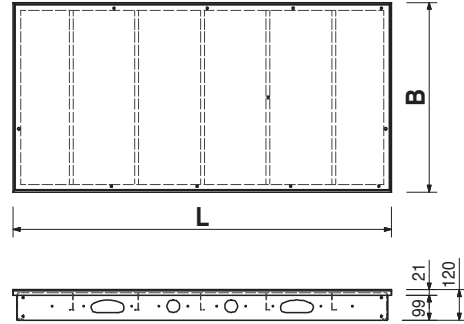
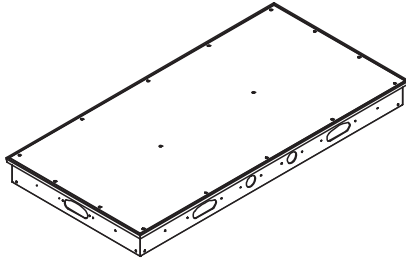

061100	15,500	Main Beam SLT 225 For standard fields.
--------	--------	--

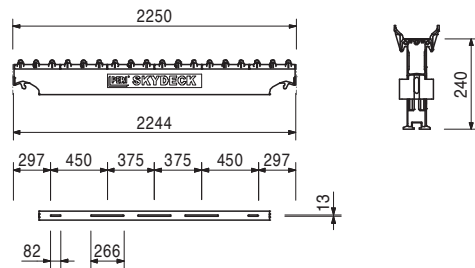
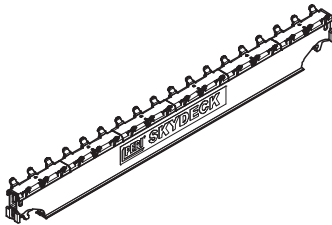

061160	25,500	Main Beam SLT 375 For cantilevers.
--------	--------	--

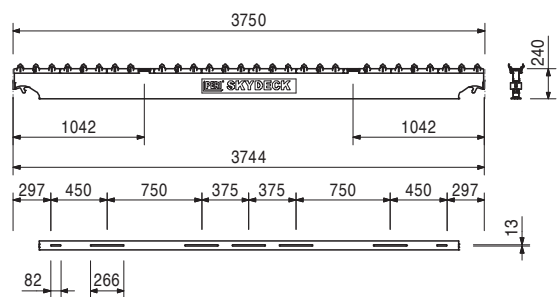
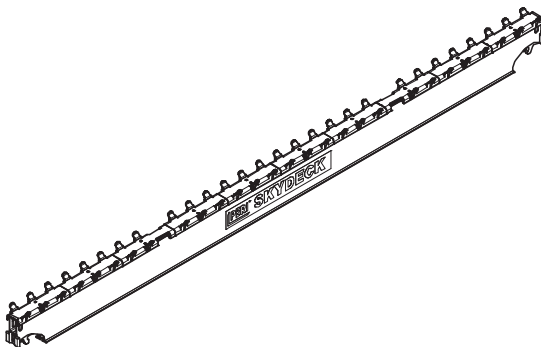

Item no.	Weight kg
061110	9,690

Main Beam SLT 150
For filler areas.

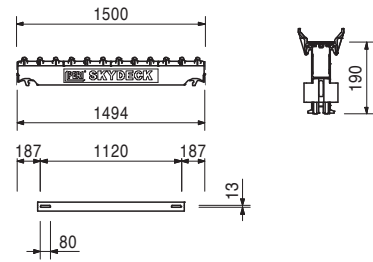
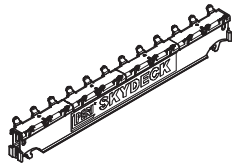

Item no.	Weight kg	Product Name	L
061026	1,690	Cover Strip SAL	1500
061027	0,849	Cover Strip SAL 150	750
061024	0,561	Cover Strip SAL 75	500
061038	0,427	Cover Strip SAL 37,5	375
061028	1,990	Cover Strip SAL 150/27	1500
061029	0,996	Cover Strip SAL 75/27	750
061039	0,501	Cover Strip SAL 37,5/27	375

Cover strip made of plastic for 21 or 27 mm form-lining. For use with Drophead SFK or SFK/27.

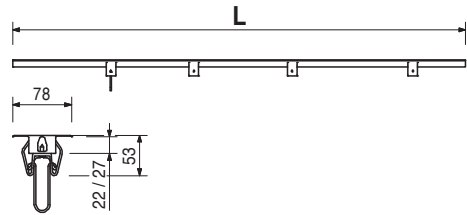
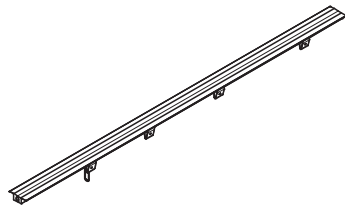

061045	5,740	Edge Beam SRT-2
061046	2,720	Edge Beam SRT-2 150
061047	5,770	Edge Beam SRT-2 75
061048	2,730	Edge Beam SRT-2 150/27
		Edge Beam SRT-275/27

For longitudinal and transverse infilling as well as forming around columns. For compensations with 21 or 27 mm formlining.

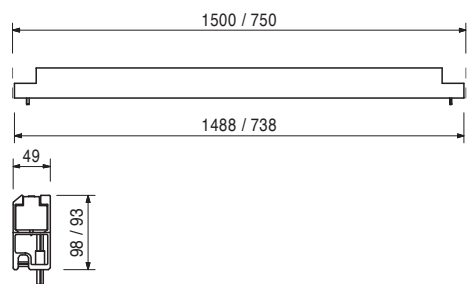
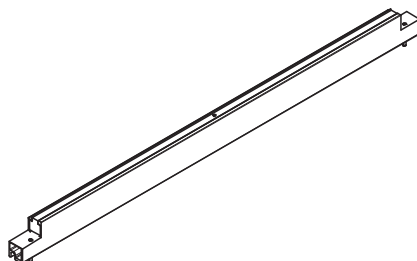

Item no. Weight kg

061210 6,180
061035 6,050

Dropheads SFK

Drophead SFK

Drophead SFK/27

With self-locking coupling. Supports main beam as well as cover strip or formlining. Lowering range 6 cm. For 21 or 27 mm formlining.

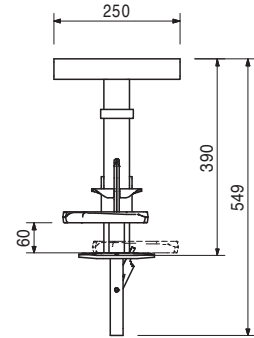
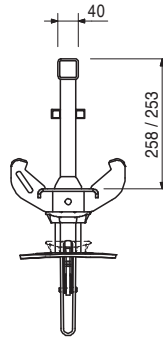
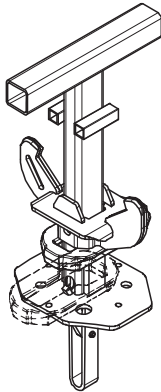

061200 3,860

Prophead SSK

With self-locking coupling. Supports panel, main beam, edge beam and filler timber.

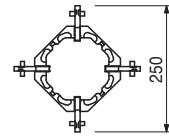
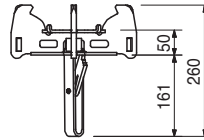
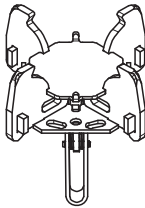

061180 5,340

Combihead SCK

With self-locking coupling. Supports panel, main beam, edge beam and filler timber.

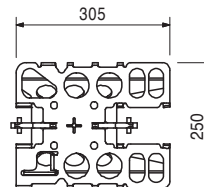
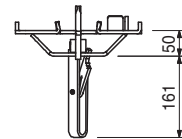
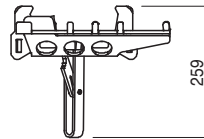
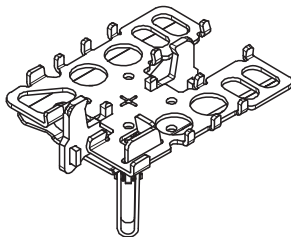

Item no. Weight kg

061049	3,350
061036	5,020
061050	3,080
061040	4,620

Filler Timbers SPH

Filler Timber SPH 150

Filler Timber SPH 225

Filler Timber SPH 150/27

Filler Timber SPH 225/27

For compensations with 21 or 27 mm formlining.

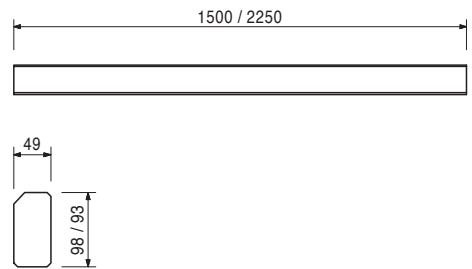
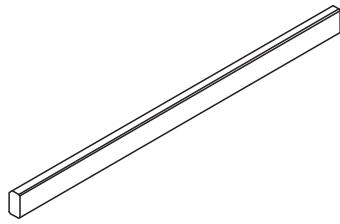

061021	8,650
061022	5,340
061015	7,870
061016	4,900

Triangular Frames SDR

Triangular Frame SDR 150 x 75

Triangular Frame SDR 75 x 75

Triangular Frame SDR 150 x 75/27

Triangular Frame SDR 75 x 75/27

For compensations on inclined walls. For compensations with 21 or 27 mm formlining.

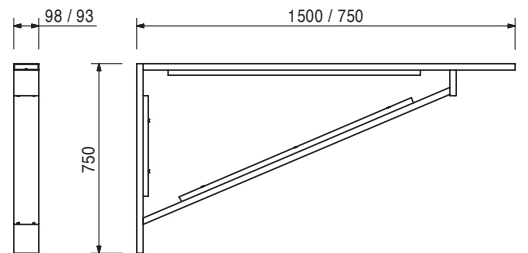
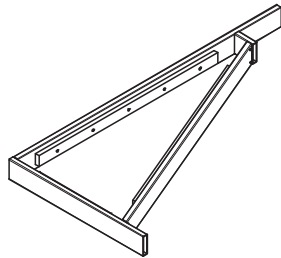



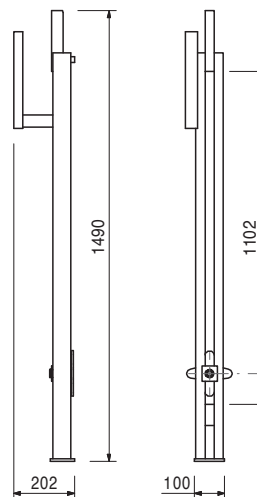
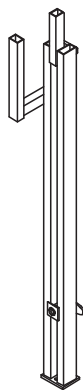

061051	5,250
--------	-------

Wall Holder SWH-2

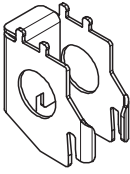
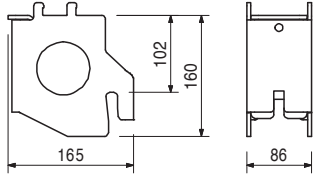
Attach to every second beam or panel.

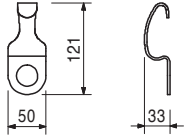

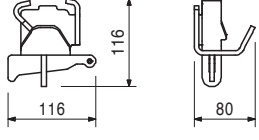
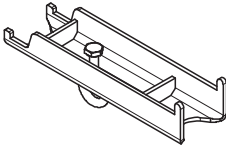
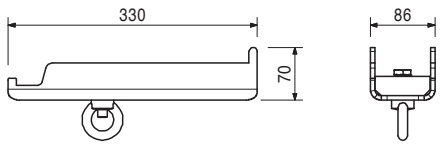
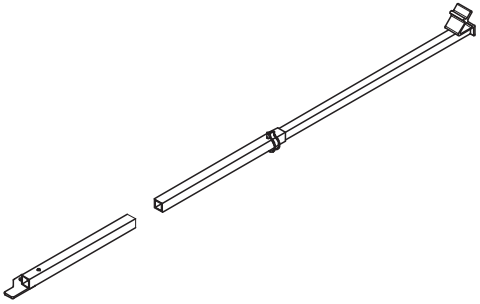
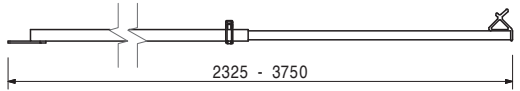
Item no.	Weight kg	
061023	2,140	<p>End Support SSL For transition to compensation. For connecting to the Drophead SKF.</p>  
061290	0,133	<p>Panel Clip SPK Fixes panels on main beam.</p>  
061280	0,780	<p>Panel Wedge Clip SPKK Fixes panels on main beam.</p>  
061052	2,590	<p>Table Connector STV For assembling SKYDECK slab tables. Also used for mounting intermediate props to the main beams.</p>  
061300	2,240	<p>Shuttering Aid SSH For forming with SKYDECK. Adjustable in 7.5 cm increments.</p>  

Item no.	Weight kg
061310	0,996

Tension Sleeve SAO
For bracing cantilevered main beams.

Technical Data
Permissible tension load 3.0 kN.

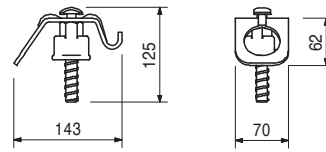

061060	108,000
--------	---------

Platform SDB 150
Working and safety scaffold. Scaffold width 1.30m. With continuous 39 mm thick scaffold boards and folding handrail frame.

Technical Data
Permissible load capacity of 150 kg/m².

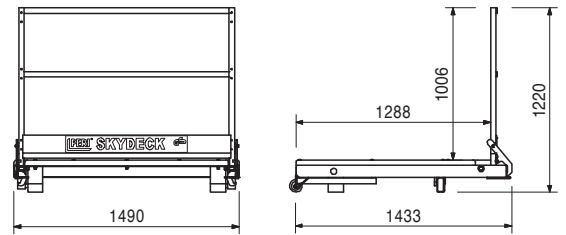
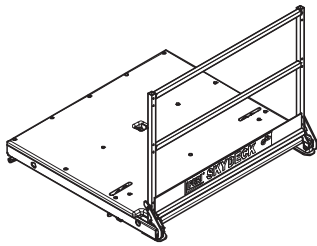

061061	153,000
--------	---------

Platform SDB 225
Working and safety scaffold. Scaffold width 1.30m. With continuous 39 mm thick scaffold boards and folding handrail frame.

Technical Data
Permissible load capacity of 150 kg/m².

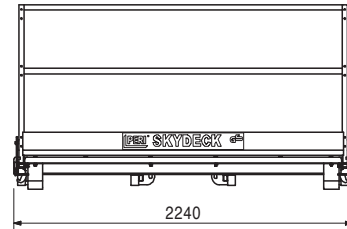
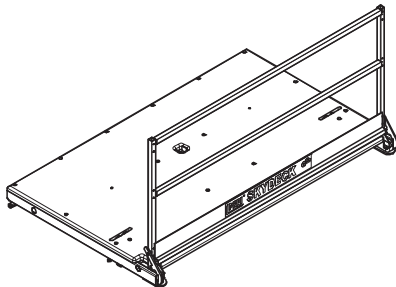

061062	185,000
--------	---------

Platform SDB 300
Working and safety scaffold. Scaffold width 1.30m. With continuous 39 mm thick scaffold boards and folding handrail frame.

Technical Data
Permissible load capacity of 150 kg/m².

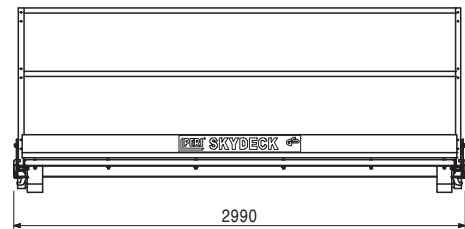
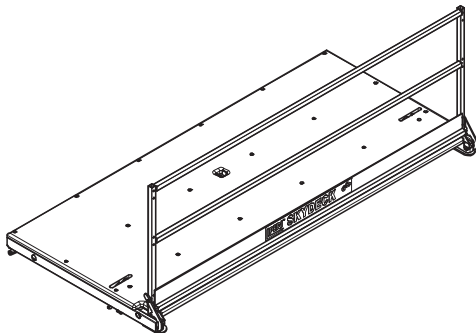

Item no.	Weight kg
061250	4,760

Guardrail Holder SGH, Alu
For assembling a guardrail with SKYDECK.

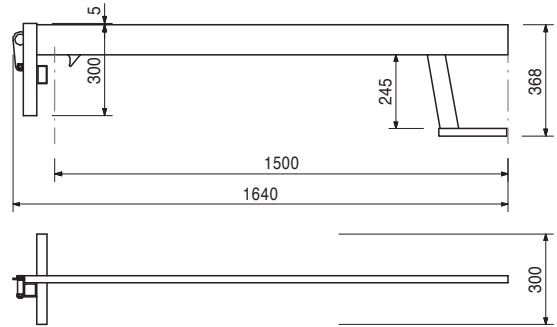
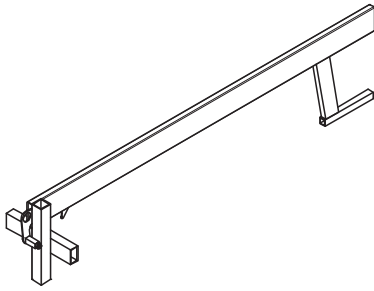

061260	6,120
--------	-------

Accessories
Guardrail Post SGP

061260	6,120
--------	-------

Guardrail Post SGP
As guardrail for different systems.

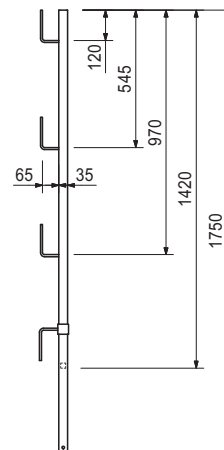

065073	1,370
--------	-------

Anchor Chain 3.0 kN, l = 2.5 m

Technical Data

Permissible tension load 3.0 kN.

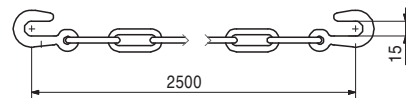
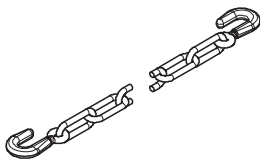

065074	0,450
--------	-------

Turnbuckle 3.0 kN, M 12

Technical Data

Permissible tension load 3.0 kN.

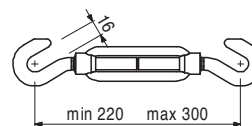
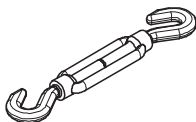

Item no.	Weight kg
028100	1,830

Base Plate RS

For mounting the RS Push-Pull Props.

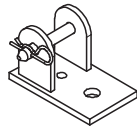

Complete with

1 pc. 018050 Pin \varnothing 16 x 65/86, galv.
1 pc. 018060 Cotter Pin 4/1, galv.

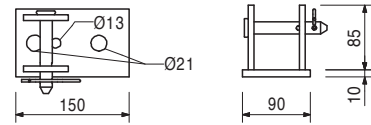

061530	82,400
--------	--------

Pallet SD 150 x 225, galv.

For stacking and transportation of 48 SKYDECK Panels 150 x 75. With 5 tension straps.

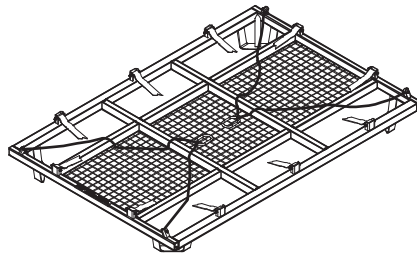

Safety instructions

Follow Instructions for Use!

Load-carrying equipment according to BGR 500.
Permissible load 0.75 t.

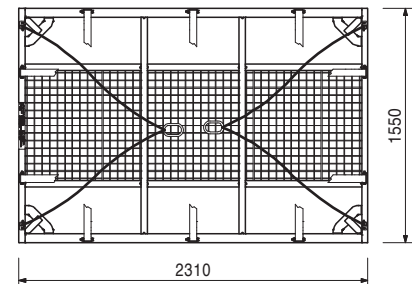
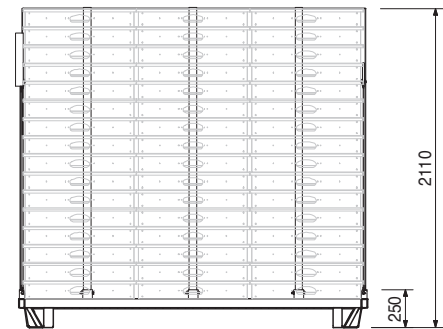

061500	76,700
--------	--------

Pallet SD 150 x 75, galv.

For stacking and transportation of 14 SKYDECK Panels 150 x 75.

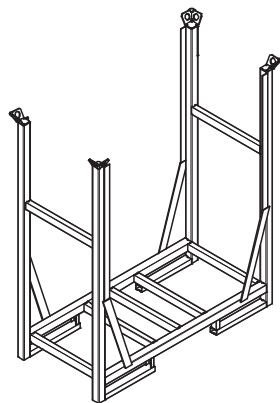

Safety instructions

Follow Instructions for Use!

Load-carrying equipment according to BGR 500.
Permissible load 1.0 t.

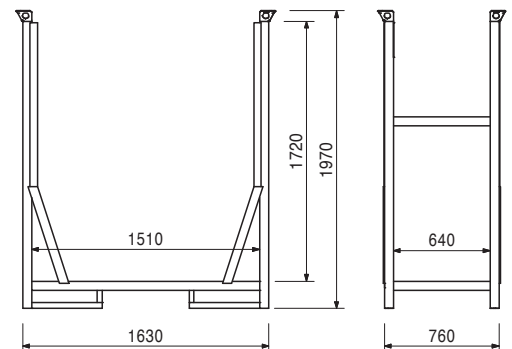

Item no.	Weight kg
061510	110,000

Pallet Lifting Trolley 1500 mm
For moving pallets and crate pallets.

Technical Data
Length of forks 1500 mm, support width of forks 520 mm, lifting range 85 - 195 mm, permissible load 2.0 t.

Safety instructions
Lifting equipment according to BGV D8.

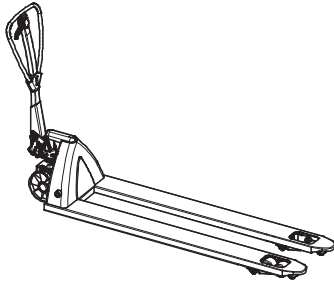

061520	403,000
--------	---------

Transportation Fork SKYDECK SUG, galv.
For moving SKYDECK slab tables.

Safety instructions
Follow Instructions for Use.
Load-carrying equipment according to BGR 500.
Permissible load 1.0 t.

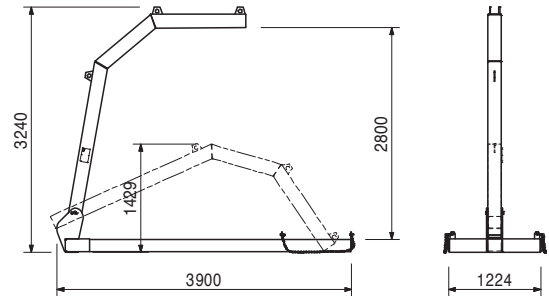
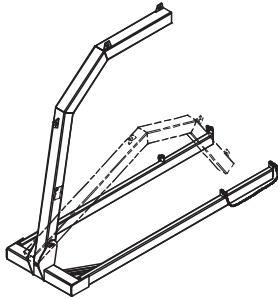

035500	72,800
--------	--------

Stripping Cart Alu
Mobile working scaffold. Height adjustable in 25 cm increments. Platform height: max. 2.0 m.

Technical Data
Permissible load 100 kg/m².

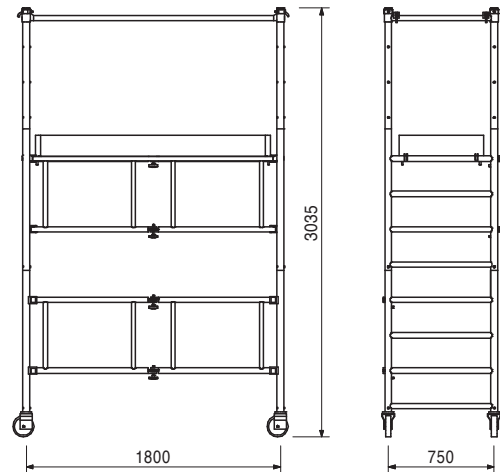
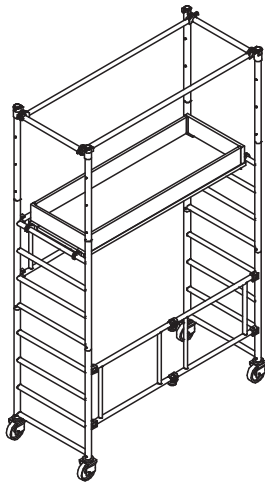

Item no.	Weight kg
102031	363,000

Stripping Cart ASW 465, complete

Mobile working scaffold. Height adjustable in 30 cm increments. Platform height: max. 4.65 m. Packed in: Ring Pallet USP 104, Item no. 100678, with 1 x lashing strap, Item no. 100707 and 4 pcs. Scaffold Tube, Item no. 026411.

Complete with

- 1 pc. 102033 Steel Traverse 140/220 ASW
- 1 pc. 102025 Folding Base Unit 160/190 ASW
- 6 pcs. 102035 Vertical Frames 70/90 ASW
- 2 pcs. 102026 Entry Platforms 190 ASW
- 1 pc. 102030 Toe Board Set 70/190 ASW
- 4 pcs. 102027 Double Handrails 190 ASW
- 3 pcs. 102028 Diagonal Braces 210 ASW
- 2 pcs. 102029 Horizontal Braces 190 ASW
- 8 pcs. 102037 Wind Securing Clip 60 ASW
- 12 pcs. 102807 Ballast 10 kg ASW

Technical Data

Load-carrying equipment according to BGR 500.
Permissible load: 100 kg/m².

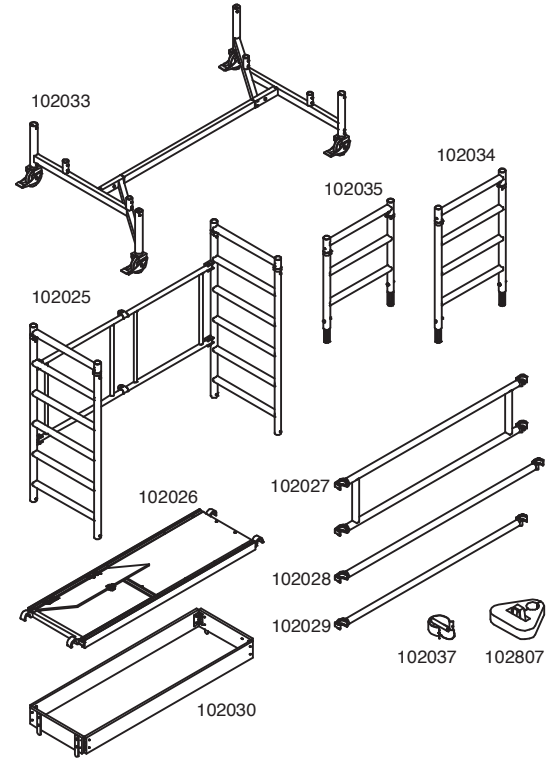
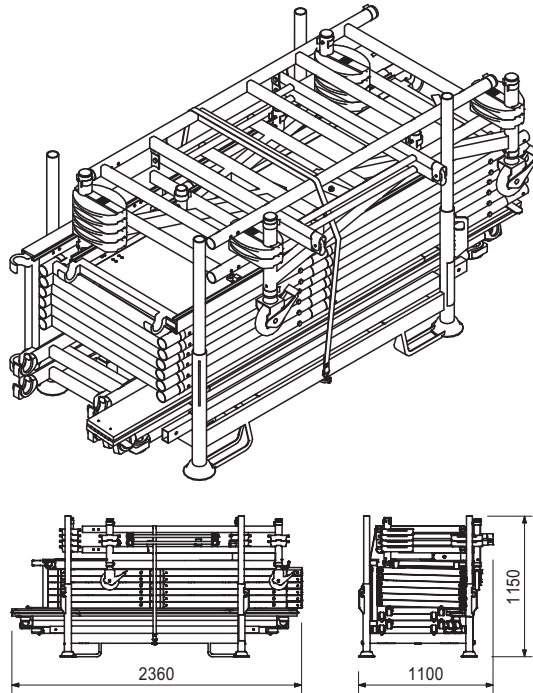



01 PERI GmbH
Rudolf-Diesel-Strasse
89264 Weissenhorn
info@peri.com
www.peri.com



02 France
PERI S.A.S.
Zone Industrielle Nord
34-36 rue des Frères Lumière
77109 Meaux Cedex
peri.sas@peri.fr
www.peri.fr

03 Switzerland
PERI AG
Aspstraße 17
8472 Ohringen
info@peri.ch
www.peri.ch

04 Spain
PERI S.A. Sociedad
Unipersonal
Ctra. Paracuellos -
Fuente el Saz km. 18,9
Cno. de Malatones, km. 0,5
28110 Algete/Madrid
info@peri.es
www.peri.es

05 Belgium/Luxembourg
N.V. PERI S.A.
Industriepark
Nijverheidsstraat 6 PB 54
1840 Londerzeel
info@peri.be
www.peri.be

06 Netherlands
PERI B.V.
v. Leeuwenhoekweg 23
Postbus 304
5480 AH-Schijndel
info@peri.nl
www.peri.nl

07 USA
PERI Formwork Systems, Inc.
7135 Dorsey Run Road
Elkridge, MD 21075
info@peri-usa.com
www.peri-usa.com

08 Indonesia
PT Beton Perkasa Wijaksana
P.O. Box 3737
Jakarta 10210
bpw@betonperkasa.com
www.peri.de

09 Italy
PERI S.p.A.
Via G. Pascoli, 4
20060 Basiglio (MI)
info@peri.it
www.peri.it

10 Japan
PERI Japan K.K.
7F Hakozaki 314 Building,
31-4 Hakozaki-cho,
Nihonbashi Chuo-ku
Tokyo 103-0015
info@perijapan.jp
www.perijapan.jp

11 United Kingdom/Ireland
PERI Ltd.
Market Harborough Road
Clifton upon Dunsmore
Rugby, CV23 0AN
info@peri.ltd.uk
www.peri.ltd.uk

12 Turkey
PERI Kalip ve İskeleleri
San. ve Tic. Ltd. Sti.
Çakmaklı Mahallesi
Akçaburgaz Cad.
72. Sokak No: 23
**Kıraç - Büyükkçekmece/
Istanbul 34500**
info@peri.com.tr
www.peri.com.tr

13 Hungary
PERI Kft.
Zádor u. 4.
1181 Budapest
info@peri.hu
www.peri.hu

14 Malaysia
PERI Formwork Malaysia
Sdn. Bhd.
Unit 19-07-4, Level 7
PNB Damansara
19 Lorong Dungun
Damansara Heights
50490 Kuala Lumpur
info@perimalaysia.com
www.perimalaysia.com

15 Singapore
PERI ASIA Pte. Ltd
Formwork Pte. Ltd.
No. 1 Sims Lane # 06-10
Singapore 387355
pha@periasia.com
www.periasia.com

16 Austria
PERI Ges.mbh
Traisenstraße 3
3134 Nußdorf ob der Traisen
office@peri.at
www.peri.at

17 Czech Republic
PERI spol. s r.o.
Průmyslová 392
252 42 Jesenice
info@peri.cz
www.peri.cz

18 Denmark
PERI Danmark A/S
forskalling og stillads
Greve Main 26
2670 Greve
peri@peri.dk
www.peri.dk

19 Finland
PERI Suomi Ltd. Oy
Hakakalliontie 5
05460 Hyvinkää
info@perisuomi.fi
www.perisuomi.fi

20 Norway
PERI NORGE AS
Dråpen 9
3036 Drammen
info@peri.no
www.peri.no

21 Poland
PERI Polska Sp. z o.o.
ul. Stoleczna 62
05-860 Plochocin
info@peri.pl.pl
www.peri.pl.pl

22 Sweden
PERIFORM SVERIGE AB
Montörgatan 4-6
Box 9073
30013 Halmstad
peri@periform.se
www.periform.se

23 Korea
PERI (Korea) Ltd.
8-9th Fl., Yuseong Bldg.
830-67, Yeoksam-dong,
Kangnam-ku,
Seoul 135-080
info@perikorea.com
www.perikorea.com

24 Portugal
PERIcofragens Lda.
Cofragens e Andaimes
Rua Cesário Verde,
nº 5 - 3º Esq.
**Linda-a-Pastora
2790-326 Queijas**
info@peri.pt
www.peri.pt

25 Argentina
PERI S.A.
Ruta Nacional N° 9, km 47,5
(Panamericana Ramal Escobar)
(1625) Escobar/Prov. Bs. As.
info@peri.com.ar
www.peri.com.ar

26 Brazil
PERI Formas e
Escoramentos Ltda.
Rodovia Raposo Tavares,
km 41
Colinas Bandeirante
**CEP 06730-000
Vargem Grande Paulista
São Paulo**
info@peribrasil.com.br
www.peribrasil.com.br

27 Chile
PERI Chile Ltda.
C/José de San Martín N° 104
Parque Industrial Los
Libertadores
Colina, Santiago de Chile
perich@peri.cl
www.peri.cl

28 Romania
PERI România SRL
Calea Bucureşti nr. 2B
077015 Baloteşti - ILFOV
info@peri.ro
www.peri.ro

29 Slovenia
PERI SLOWENIEN
Goran Opalic
Obrežna 137
2000 Maribor
peri.slo@triera.net
www.peri.de

30 Slovakia
PERI spol. s r.o.
Šamorínska 18
903 01 Senec
info@peri.sk
www.peri.sk

31 Australia
PERI Australia Pty. Ltd.
116 Glendenning Road
Glendenning NSW 2761
info@periaus.com.au
www.periaus.com.au

32 Estonia
PERI AS
Valdmäe 8
Taanassilma Tehnopaik
76401 Saku vald
Harjumaa
peri@peri.ee
www.peri.ee



- 33 Greece**
 PERI Hellas Ltd.
 Sokratous Str.
 5th kil. Koropi-Varis Ave.
 P. O. Box 407
194 00 Koropi
 info@perihellas.gr
 www.perihellas.gr
- 34 Latvia**
 PERI SIA
 Granita 26
1057 Riga
 info@peri-latvija.lv
 www.peri-latvija.lv
- 35 United Arab Emirates**
 PERI (L.L.C.)
 Brashy Building,
 Office No. 212
 Shk. Zayed Road
 P.O. Box 27933
Dubai
 perillc@perime.com
 www.perime.com
- 36 Canada**
 PERI Formwork Systems, Inc.
 45 Nixon Road
Bolton, Ontario
L7E 1K1
 info@peri.ca
 www.peri.ca
- 37 Libanon**
 PERI GmbH
 Lebanon Representative
 Office
 AYA Commercial Center,
 7th floor,
 Dora Highway,
Beirut
 P.O. Box 90 416 Jdeidet
 lebanon@peri.de
 www.peri.de
- 38 Lithuania**
 PERI UAB
 Titnago st. 19
02300 Vilnius
 info@peri.lt
 www.peri.lt
- 39 Marocco**
 PERI S.A.
 Route de Rabat, km. 5
 Piste de Beni Touzine
Tanger
 peri25@menara.ma
 www.peri.de
- 40 Israel**
 PERI Formwork
 Engineering Ltd
 16 Moshe Dayan st.,
 P.O. Box 10202
 Petach Tikva,
49002 Israel
 info@peri.co.il
 www.peri.co.il
- 41 Bulgaria**
 PERI BULGARIA EOOD
 Kv. Vragdebna
 m. Nova Machala Nr. 46
1839 – Sofia
 peri.bulgaria@peri.bg
 www.peri.bg
- 42 Iceland**
 MEST Ltd.,
 Fornubudum 5
220 Hafnarfjordur
 mest@mest.is
 www.mest.is
- 43 Kazakhstan**
 TOO PERI Kazakhstan
 Rubenstein Street 10
 (Corner Dostyk Str. 7)
050010 Almaty
 peri@peri.kz
 www.peri.kz
- 44 Russian Federation**
 OOO PERI
 8 Etage, OOO PERI Buro
 Krasnaya Presnya Str. 24
123022 Moskau
 moscow@peri.ru
 www.peri.ru
- 45 South Africa**
 PERI Wiehahn (Pty.) Ltd.
 P.O. Box 2668
Bellville 7535
 ask@wiehahn.co.za
 www.periwiehahn.co.za
- 46 Ukraine**
 TOW PERI Ukraina
 23, M. Raskowa Str., B. 822
02002 Kiew
 peri@peri.ua
 www.peri.ua
- 47 Egypt**
 PERI GmbH
 Egypt Branch Office
 24 A, Obour Gardens,
 4th Floor, apt. # 1
 Salah Salem Street
11361 Heliopolis
Cairo
 info@peri.com.eg
 www.peri.com.eg
- 48 Serbia**
 PERI Oplate d.o.o.
 Jurija Gagarina 81
11070 Novi Beograd
 office@peri.co.yu
 www.peri.co.yu
- 49 Mexico**
 PERI Cimbras y Andamios,
 S.A. de C.V.
 Parque de las Américas
 KM 3.5 Carretera
 Jorobas – Tula
 Huehuetoca
Estado de México,
C.P. 54680
 info@peri.com.mx
 www.peri.com.mx
- 50 Azerbaijan**
 PERI Kalıp ve İskeleleri
 Baku Branch Office
 28 May Küç. Ev 72 Menzil 27
Baku
 peribaku@peri.com.tr
 www.peri.com.tr
- 51 Turkmenistan**
 PERI Kalıp ve İskeleleri
 Aşgabat Branch Office
 Görogly Sokak No. 130, Kat 2
744035 Aşgabat
 periashgabat@peri.com.tr
 www.peri.com.tr
- 52 Belorussia**
 PERI Belarus
 Pr. Nesawisimosti 11
 Kopus-2 Zimmer: 526,528
220030 Minsk
 peri@mail.belpak.by
 www.peri.com.tr
- 53 Croatia**
 PERI oplate i skele d.o.o.
 Dolenica 20
10 250 Donji Stupnik/
Zagreb
 info@peri.com.hr
 www.peri.com.hr
- 54 Iran**
 PERI GmbH
 Iran Branch Office
 Flat 27, 5th floor, KAVE BLVD,
 Building No. 4
 P.O. Box 1939793669
Teheran-Iran
 iran@peri.ir
 www.peri.ir
- 55 India**
 PERI (India) Pvt Ltd
 717 Palm Springs
 Palm Court
 Malad Link Road
 Malad (West)
Mumbai – 400064
 info@peri.in
 www.peri.in
- 56 Jordan**
 PERI Jordan
 Saad 5 Center, 4th Floor
 Office No. 404
 Al Madineh
 Al Munawara Street
 P.O. Box 367
11947 Amman
 jordan@peri.de
 www.peri.de
- 57 Kuwait**
 PERI Kuwait
 Arraya Center, 29th Floor
 Al-Shuhada Street, Sharq
 P.O. Box 1060 Safat
13011 Kuwait
 kuwait@peri.de
 www.peri.de
- 58 Saudi Arabia**
 PERI Saudi Arabia
 33 AL-Batraa Street
 AL - Shurbatiy Building
 AL - Bughdadiyah AL -
 Gharbiah Distrect
 6th Floor, Flat # 61
 P.O. Box 11641
Jeddah
 saudi-arabia@peri.de
 www.peri.de
- 59 Qatar**
 PERI Qatar LLC
 P.O. Box 24133
Doha
 qatar@peri.de
 www.peri.de
- 60 Algeria**
 Société PERI S.A.S.
 Bureau de liaison d'Alger
 50 bis, Route de Gué
 de Constantine
 Hai El Badr (ex Apreval)
 Immeuble FADLI
Kouba - Alger
 peri.alger@peri.fr
 www.peri.fr
- 61 Albania**
 Autostrada TIRANE-DURRES
 Km 2 Rr dytesore
 ne krah te Vodafonit
 Perballe ARDENOS FUSHE -
 MEZES TIRANE
Tirane / ALBANIA
 info@peri.com.tr
 www.peri.com.tr
- 62 Peru**
 Av. Defensores
 del Morro 2074
 Chorrillos
 Lima
Peru
 jeanpierre.saux@peri.com.pe

PERI Product Range



Wall Formwork

Panel Formwork
Girder Formwork
Circular Formwork
Facade Formwork
Brace Frame



Climbing Systems

Climbing Scaffold
Self-Climbing System
Climbing Protection Panel
Platform Systems



Column Formwork

Square
Rectangular
Circular



Scaffold, Stairways, Working Platforms

Facade Scaffold
Working Platform
Weather Protection Roof
Stairway Access



Slab Formwork

Panel Formwork
Beam Grid Formwork
Girder Formwork
Slab Table
Beam Formwork



Bridge and Tunnel Formwork

Cantilevered Parapet Carriage
Cantilevered Parapet Platform
Engineer's Construction Kit



Shoring Systems

Steel Slab Props
Aluminium Slab Props
Tower Systems
Heavy-Duty Props



Services

Formwork Assembly
Cleaning / Repairs
Formwork Planning
Software
Statics
Special Constructions

Additional Systems
Plywood
Formwork Girders
Stopend Systems
Pallets
Transportation Containers



PERI GmbH Formwork Scaffolding Engineering

P.O. Box 1264
89259 Weissenhorn
Germany
Tel +49 (0)73 09.9 50-0
Fax +49 (0)73 09.9 51-0
info@peri.com
www.peri.com